

DOCUMENTATION

**LOW PRESSURE BACK PRESSURE REGULATOR
SPRING OPERATED**

LP 4 - 0

Manual : 582.152.110-UK - 1912

Date: 16/12/19

Supersede :

Modif.:

TRANSLATION FROM THE ORIGINAL MANUAL

IMPORTANT : Before assembly and start-up, please read and clearly understand all the documents relating to this equipment (professional use only).

THE PICTURES AND DRAWINGS ARE NON CONTRACTUAL. WE RESERVE THE RIGHT TO MAKE CHANGES WITHOUT PRIOR NOTICE.

SAMES KREMLIN SAS
13, chemin de Malacher
38 240 - MEYLAN - France
 : 33 (0)4 76 41 60 60

www.sames-kremlin.com



INSTRUCTION MANUAL

**LOW PRESSURE BACK PRESSURE REGULATOR
SPRING OPERATED
MODEL : 4 - 0**

Manual P.N° : 1912 573.010.112

TRANSLATION FROM THE ORIGINAL MANUAL

Date : 04/12/19 - Supersede : 21/09/10 - Modif. Update

Dear customer,

We thank you very much for purchasing an accessory from SAMES KREMLIN range.

To get the best result, safe and efficient operation of your LP back pressure regulator, we advise you to read and make yourself familiar with this instruction and service manual.

1. SAFETY INSTRUCTIONS

- ➔ The personnel involved in operating and servicing this equipment must be aware of all the safety requirements stated in this manual. The workshop supervisor must be certain that the personnel has perfectly understood the safety instructions and complies with them.
- ➔ Use the equipment only in a properly ventilated area to maximize health care. Any misuse of the spray equipment or accessories can damage them and result in serious body injury, fire or explosion hazard.
- ➔ This equipment is installed on installations operating under low pressures. Check the maximum pressure of the fluid pressure supplied upstream of the regulator.
- ➔ All fittings must be tight and in good condition.
- ➔ Before cleaning or removing components of the equipment, it is compulsory :
 - to stop the pump by shutting off the compressed air supply.
 - to open the drain valve.
 - to point the spray gun into an appropriate waste receptacle and press the trigger to depressurize the system.

SAMES KREMLIN SAS

13, chemin de Malacher
38 240 - MEYLAN - France

☎ : 33 (0)4 76 41 60 60

www.sames-kremlin.com

2. TECHNICAL CHARACTERISTICS

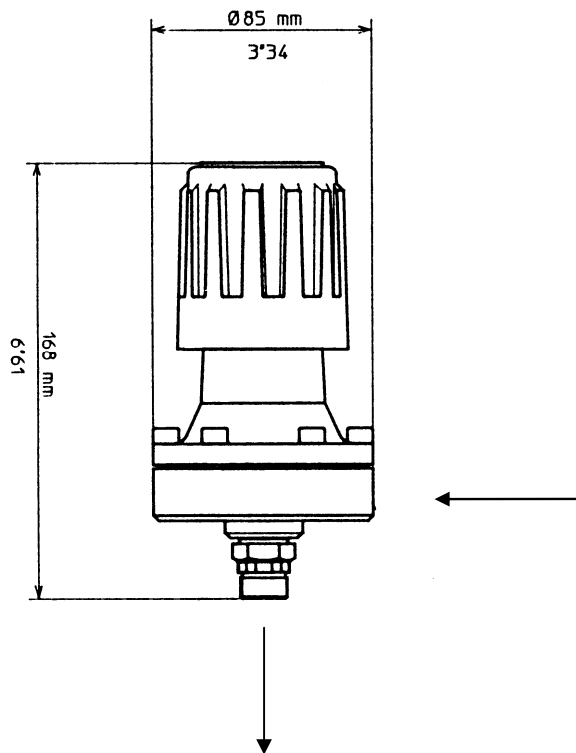

The LP back pressure regulator enables to regulate a constant pressure in a circulating system.

Thanks to its large diaphragm, the fluid regulation is accurate.

This regulator is designed for a full and easy flushing.

The adjustment is carried out by means of a phosphore knob.

Weight	1 300 g / 46 oz	
Fluid outlet	Supplied with M 1/4 BSP+ fitting according to requirements	At the fluid outlet, install one of the fittings supplied with regulator (fitting M 18 x 125 or 3/8 NPS or 3/8 BSP). When mounting the fitting apply some Loctite 222 on thread.
Fluid inlet	F 1/4 BSP	
Gauge port	F 1/4 BSP	
Bracket support - Hole Ø	9 mm / 11/32"	
Maximum regulated fluid pressure	4 bar / 58 PSI	
Wetted parts	Stainless steel Carbide PTFE	

3. TROUBLESHOOTING CHART

TROUBLE	CAUSE	SOLUTION
Overpressure upstream of the regulator	Adjustment knob over screwed	Unscrew the adjustment knob according to the upstream pressure.
	Pressure too high in the circulating system	Release pressure in the circulating system.
Pressure drop upstream of the regulator	Improper fluid proofness between seat and ball.	Clean and reinstall.
	Adjustment knob not enough screwed	Screw adjustment knob.
Irregular circulation	Too much pulsation in the circulating system.	Check circulating system.
	Improper proofness between seat and ball.	Clean or replace.
Material leakage along the regulator hat	Defective diaphragm	Replace
	Loosen lower spring support.	Tighten.

4. DISASSEMBLY

■ SEAT (3) REPLACEMENT

Unscrew fluid outlet fittings (5 and 2)

Remove seal (6), seat (3) and flat seal (4).

Replace seals.

Clean parts with white spirit solvent.

Reinstall parts in reverse. Be certain the flat seal is properly located.

➔ **The seat is reversible. When servicing the first time it can be installed upside down. It will have to be replaced only at second servicing.**

■ DIAPHRAGM (7) REPLACEMENT

Unscrew the 6 screws (9).

Remove hat (21), upper spring support (20) and spring (19).

Unscrew nut (8).

Remove lower spring support (10).

Remove diaphragm (7).

Clean parts with white spirit solvent.

Reassemble parts in reverse.

Doc. 573.010.112 Date/Datum/Fecha : 04/12/19 Annule/Cancel/ Ersetzt/Anula : 08/02/02	Modif. / Änderung : Mise à jour / Update / Aktualisierung / Actualización	Pièces de rechange Spare parts list Ersatzteilliste Piezas de repuesto
--	--	---

LOW PRESSURE BACK PRESSURE REGULATOR (SPRING OPERATED) - MODEL : 4 - 0:
- Stainless steel P.N° : 155.610.100

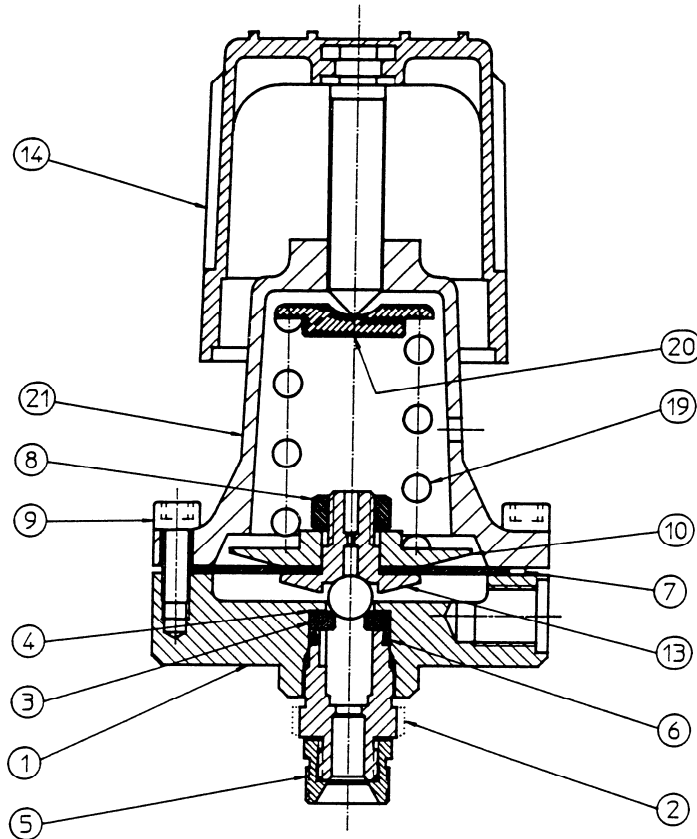

Ind.	Part number	Description	Qty	Ind.	Part number	Description	Qty
1	055 610 001	Lower body	1	14	055 610 017	Adjustment knob (phosphore)	1
2	055 610 002	Fitting, valve	1	17	050 319 502	Spring, 9 bar / 131 psi	1
3	055 610 004	Seat	1	20	016 200 004	Upper spring support	1
4	055 610 005	Flat seal	1	21	016 200 100	Hat	1
5	---	Fitting (fluid outlet) :	1			OPTIONAL	
-	029 020 007	. 18 x 125 M, stainless steel	1		016 200 010	Bracket	1
-	029 020 008	. 3/8 NPS M, stainless steel	1			Gauge kit :	
-	029 020 009	. 3/8 BSP M, stainless steel	1		050 470 101	Elbow, MF 1/4, stainless steel	1
6	050 040 314	Seal, PTFE	1		050 081 701	Nipple, 1/4"- length 150mm / 5" 29/32 - stainless steel	1
7	055 170 005	Diaphragm	1		050 470 301	Coupling, 1/4", stainless steel	1
8	953 010 021	Nut, HM 10	1		910 011 402	Gauge, 0-6 bar / 0-88 psi	1
9	933 151 196	Screw, CHc M 6 x 16	6				
10	055 170 006	Lower spring support	1				
13	155 610 101	Ball assembly	1				