

DOCUMENTATION

GUN

A 35

PNEUMATIC

Manual: 582.057.110 – UK - 2102

Date: 11/02/21

Annule : 14/05/19

Modif. :

TRANSLATION FROM THE ORIGINAL MANUAL

IMPORTANT: Before assembly and start-up, please read and clearly understand all the documents relating to this equipment (professional use only).

THE PICTURES AND DRAWINGS ARE NON CONTRACTUAL. WE RESERVE THE RIGHT TO MAKE CHANGES WITHOUT PRIOR NOTICE.

SAMES KREMLIN SAS

13, chemin de Malacher
38 240 - MEYLAN - France

 : 33 (0)4 76 41 60 60

www.sames-kremlin.com



<p align="center">FR</p> <p>Pour une utilisation sûre, il est de votre responsabilité de :</p> <ul style="list-style-type: none"> • D'installer, d'utiliser, d'entretenir et de réparer l'équipement conformément aux préconisations de SAMES KREMLIN ainsi qu'aux réglementations nationales et/ou locales, • Vous assurez que les utilisateurs de cet équipement ont été formés, ont parfaitement compris les règles de sécurité et qu'ils les appliquent. 	<p align="center">UK</p> <p>To ensure safe use of the machinery, it is your responsibility to:</p> <ul style="list-style-type: none"> • Install, use, maintain and repair the machinery in accordance with SAMES KREMLIN's recommendations and national and/or local regulations, • Make sure that the users of the machinery have received proper training and that they have perfectly understood the safety rules and apply them. 	<p align="center">DE</p> <p>Eine sichere Nutzung setzt voraus, dass Sie: :</p> <ul style="list-style-type: none"> • die Anlage im Einklang mit den Empfehlungen von SAMES KREMLIN sowie mit den nationalen und/oder lokalen Bestimmungen installieren, verwenden, warten und reparieren, • sich vergewissern, dass die Nutzer dieser Anlage angemessen geschult wurden, die Sicherheitsbestimmungen verstanden haben und sie anwenden.
<p align="center">ES</p> <p>Para una utilización segura, será de su responsabilidad:</p> <ul style="list-style-type: none"> • instalar, utilizar, efectuar el mantenimiento y reparar el equipo con arreglo a las recomendaciones de SAMES KREMLIN y a la normativa nacional y/o local, • cerciorarse de que los usuarios de este equipo han recibido la formación necesaria, han entendido perfectamente las normas de seguridad y las aplican. 	<p align="center">IT</p> <p>Per un uso sicuro, vi invitiamo a:</p> <ul style="list-style-type: none"> • installare, utilizzare, mantenere e riparare l'apparecchio rispettando le raccomandazioni di SAMES KREMLIN, nonché le normative nazionali e/o locali, • accertarvi che gli utilizzatori dell'apparecchio abbiano ricevuto adeguata formazione, abbiano perfettamente compreso le regole di sicurezza e le applichino. 	<p align="center">PT</p> <p>Para uma utilização segura, é da sua responsabilidade:</p> <ul style="list-style-type: none"> • Proceder à instalação, utilização, manutenção e reparação do equipamento de acordo com as preconizações de SAMES KREMLIN, bem como com outros regulamentos nacionais e/ou locais aplicáveis, • Assegurar-se que os utilizadores do equipamento foram devidamente capacitados, compreenderam perfeitamente e aplicam as devidas regras de segurança.
<p align="center">NL</p> <p>Voor een veilig gebruik dient u:</p> <ul style="list-style-type: none"> • het apparaat te installeren, gebruiken, onderhouden en repareren volgens de door SAMES KREMLIN gegeven aanbevelingen en overeenkomstig de nationale en/of plaatselijke reglementeringen, • zeker te stellen dat de gebruikers van dit apparaat zijn opgeleid, de veiligheidsregels perfect hebben begrepen en dat zij die ook toepassen. 	<p align="center">SE</p> <p>För en säker användning av utrustningen ansvarar ni för följande:</p> <ul style="list-style-type: none"> • Installera, använd, underhåll och reparera utrustningen enligt anvisningarna från SAMES KREMLIN och enligt nationella och/eller lokala bestämmelser. • Försäkra er om att användare av denna utrustning erhållit utbildning, till fullo förstått säkerhetsföreskrifterna och tillämpar dem. 	<p align="center">FI</p> <p>Käytön turvallisuuden varmistamiseksi velvollisuutesi on:</p> <ul style="list-style-type: none"> • Noudattaa laitteiston asennuksessa, käytössä, kunnossapidossa ja huollossa SAMES KREMLIN in suosituksia sekä kansallisia ja/tai paikallisia määräyksiä, • Varmistaa, että laitteiston käyttäjät ovat koulutettuja ja ymmärtävät täysin turvallisuusmääräykset ja miten niitä sovelletaan.
<p align="center">PL</p> <p>Dla zapewnienia bezpiecznego użytkowania na użytkownika spoczywa obowiązek:</p> <ul style="list-style-type: none"> • Instalowania, użytkowania, konserwacji i naprawy urządzenia zgodnie z zaleceniami firmy SAMES KREMLIN oraz z przepisami miejscowymi, • Upewnienia, że wszyscy przeszkoleni użytkownicy urządzenia zrozumieli zasady bezpieczeństwa i stosują się do nich. 	<p align="center">CS</p> <p>Pro bezpečné používání jste povinni:</p> <ul style="list-style-type: none"> • Nainstalovat, používat, udržovat a opravovat zařízení v souladu s pokyny firmy SAMES KREMLIN a s národními a/nebo místními legislativními předpisy, • Ujistit se, že uživatelé tohoto zařízení byli vyškoleni, že dokonale pochopili bezpečnostní pravidla a že je dodržují. 	<p align="center">SL</p> <p>Za varno uporabo ste dolžni:</p> <ul style="list-style-type: none"> • inštalirati, uporabljati, vzdrževati in popravljati opremo po določilih SAMES KREMLIN in v skladu z veljavnimi nacionalnimi in/ali lokalnimi predpisi, • poskrbeti, da so uporabniki te opreme ustrezno usposobljeni, poznajo varnostne predpise in da jih upoštevajo.
<p align="center">SK</p> <p>V záujme bezpečného je vašou povinnosťou:</p> <ul style="list-style-type: none"> • nainštalovať, používať, udržiavať a opravovať zariadenie v súlade s odporúčaniami spoločnosti SAMES KREMLIN a národnými a/alebo miestnymi predpismi, • uistiť sa, že používatelia tohto zariadenia boli zaškolení, riadne porozumeli pravidlám bezpečnosti a používajú ich. 	<p align="center">HU</p> <p>A biztonságos használat érdekében az Ön felelőssége, hogy:</p> <ul style="list-style-type: none"> • a berendezést a SAMES KREMLIN ajánlásainak valamint a nemzeti és/vagy helyi szabályozásoknak megfelelően helyezze üzembe, használja, tartsa karban és javítsa, • megbizonyosodjon róla, hogy a berendezés felhasználói képzettek, tökéletesen megértették és alkalmazzák a biztonsági előírásokat. 	<p align="center">RO</p> <p>Pentru o utilizare sigură, este responsabilitatea dvs. să:</p> <ul style="list-style-type: none"> • Instalați, utilizați, întrețineți și reparați echipamentul conform instrucțiunilor SAMES KREMLIN precum și reglementărilor naționale și/sau locale, • Vă asigurați că utilizatorii acestui echipament au fost instruiți, au înțeles perfect regulile de securitate și le aplică integral.

Declaration(s) de conformité au verso de ce document / Declaration(s) of conformity at the back of this document / Konformitätserklärung(en) auf der Rückseite dieser Unterlage

/ Declaración (es) de conformidad en el reverso de este documento / Dichiarazione/i di conformità sul retro del presente documento / Declaração(ões) de conformidade no verso do documento / Conformiteitsverklaring(en) op de keerzijde van dit document / Försäkran om överensstämmelse på omstående sida av detta dokument / Vaatimustenmukaisuusvakuutukset tämän asiakirjan kääntöpuolella / Deklaracja(e) zgodności na odwrocie dokumentu / Prohlášení o shodě se nachází/nacházejí na zadní straně tohoto dokumentu / Deklaracija(e) o skladnosti na hrbtni strani tega dokumenta / Vyhlášení/a o zhode sa nachádzajú na zadnej strane dokumentu / A dokumentum hátlapján szereplő megfelelőségi nyilatkoz(ok) / Declarații de conformitate pe versoul acestui document



DECLARATION UE DE CONFORMITE
UE DECLARATION OF CONFORMITY
EU-KONFORMITÄTSEKTLÄRUNG
DECLARACIÓN UE DE CONFORMIDAD
DICHIARAZIONE DI CONFORMITÀ UE
DECLARAÇÃO UE DE CONFORMIDADE
EU-CONFORMITEITSVERKLARING
EU-FÖRSÄKRAN OM ÖVERENSSTÄMMELSE
EU-VAATIMUKSEN MUKAISUUSVAKUUTUS
DEKLARACJA ZGODNOŚCI UE
EU PROHLÁŠENÍ O SHODĚ
IZJAVA EU O SKLADNOSTI
VYHLÁSENIE O ZHODE
EU-MEGFELELŐSÉGI NYILATKOZAT
DECLARAȚIA DE CONFORMITATE UE

Le fabricant / The manufacturer / Der Hersteller / El fabricante / Il produttore / O fabricante / De fabrikant / Tillverkare / Valmistaja / Producent / Výrobce / Proizvajalec / Výrobca / Gyártó / Fabricantul:	SAMES KREMLIN SAS 13, chemin de Malacher 38 240 - MEYLAN - FRANCE Tél. : 33 (0)4 76 41 60 60
---	--

Déclare que le matériel désigné ci-après / Herewith declares that the equipment / erklart hiermit, dass die / Declara que el material designado a continuación / Dichiaro che il materiale sottoindicato / Declara que o material a seguir designado / verklaart dat de hieronder aangeduide apparatuur

/ Kungör att den utrustning som anges här nedan / ilmoittaa, että alla mainitut laitteistot / Oświadcza, że wymienione poniżej urządzenia / Prohlašuje, že níže uvedené vybavení / Izjavlja, da je opisana oprema spodaj / Vyhlasuje, že zariadenie uvedené nižšie / Kijelenti, hogy a megjelölt anyag a továbbiakban / Declară că echipamentul precizat mai jos:

PISTOLETS AUTOMATIQUES DE PULVERISATION PNEUMATIQUES / AIRSPRAY AUTOMATIC SPRAYING GUNS
/ AUTOMATIK LUFTSPRITZPISTOLEN / PISTOLAS AUTOMÁTICAS DE PULVERIZACIÓN NEUMÁTICAS

A 25
A 25 F
A 28
A 29
A 35
A 3

Est conforme à la législation d'harmonisation de l'Union applicable suivante / Is in conformity with the relevant Union harmonisation legislation / Erfüllt die einschlägigen Harmonisierungsrechtsvorschriften der Union / es conforme con la legislación de armonización pertinente de la Unión / è conforme alla pertinente normativa di armonizzazione dell'Unione / in overeenstemming met de desbetteffende harmonisatiewetgeving van de Unie / med den relevanta harmoniserade unionslagstiftningen / on asiaa koskevan unionin yhdenmukaistamislaainsäädännön vaatimusten mukainen / jest zgodny z odpowiednimi wymaganiami unijnego prawodawstwa harmonizacyjnego / Shoduje se s následující příslušnou evropskou harmonizační legislativou

/ V skladu s harmonizirano zakonodajo Unije / Je v súlade s uplatniteľnými harmonizačnými právnymi predpismi EÚ / Megfelel a következő alkalmazandó uniós harmonizációs szabályozásnak / Este conform cu legislația aplicabilă de armonizare de mai jos

Directive ATEX / ATEX Directive / ATEX Richtlinie / Directiva ATEX / Direttiva ATEX / Diretiva ATEX / ATEX-Richtlijn / ATEX-direktivet / ATEX-direktivi / Dyrektywa ATEX / Směrnice ATEX / Direktiva ATEX / Smernica ATEX / ATEX-irányelv	 II 2G Ex h IIB T6 Gb X	2014/34/UE
NF EN ISO 80079-36 Juin 2016 NF EN ISO 80079-37 Juin 2016 NF EN 1127-1 Août 2019		
Ex h=> Protection par sécurité de construction (c) / Protection by constructional safety (c) / Schutz durch konstruktive Sicherheit (c) / Protección por seguridad constructiva (c) / Protezione per sicurezza costruttiva (c) / Protecção por segurança construtiva (c) / Bescherming door constructieveiligheid (c) / Säker konstruktion (c) / Suojaus rakenteellisella turvallisudella (c) / Zabezpieczenie za pomocą bezpieczeństwa konstrukcyjnego (c) / Ochrana bezpečnou konstrukci (c) / Zaščita s konstrukcijsko varnostjo (c) / Ochrana bezpečnou konstrukciou (c) / Szerkezetbiztonsági védelem (c) / Protecție prin securitate constructivă (c)		
INERIS 0080 - 60550 Verneuil-en-Halatte – France - 036594/21		

La présente déclaration de conformité est établie sous la seule responsabilité du fabricant / This declaration of conformity is issued under the sole responsibility of the manufacturer / Die alleinige Verantwortung für die Ausstellung dieser Konformitätserklärung trägt der Hersteller / La presente declaración de conformidad se expide bajo la exclusiva responsabilidad del fabricante / La presente dichiarazione di conformità è rilasciata sotto la responsabilità esclusiva del fabbricante / A presente declaração de conformidade é emitida sob a exclusiva responsabilidade do fabricante / Deze conformiteitsverklaring wordt verstrekt onder volledige verantwoordelijkheid van de fabrikant / Denna försäkran om överensstämmelse utfärdas på tillverkarens eget ansvar / Tämä vaatimustenmukaisuusvakuutus on annettu valmistajan yksinomaisella vastuulla / Niniejsza deklaracja zgodności wydana zostaje na wyłączną odpowiedzialność producenta / Toto prohlášení o shodě se vydává na výhradní odpovědnost výrobce / Za izdajo te izjave o skladnosti je odgovoren izključno proizvajalec / Toto vyhlásenie o zhode sa vydáva / na vlastnú zodpovednosť výrobcu / Ezt a megfelelőségi nyilatkozatot a gyártó kizárólagos felelőssége mellett adják ti / Prezenta declarație de conformitate este emisă pe răspunderea exclusivă a producătorului.



Hervé WALTER

Directeur Recherche & Développement / Research & Development Director / Direktor für Forschung & Entwicklung / Director de Investigación y Desarrollo / Direttore Ricerca e sviluppo / Diretor de Pesquisa e desenvolvimento / Manager Onderzoek en Ontwikkeling / Direktör för Forskning och Utveckling / Johtaja tutkimus ja kehitys / Dyrektor ds. Badań i rozwoju / Ředitel výzkumu a vývoje / Direktor za raziskave in razvoj / Riaditeľ pre výskum a vývoj / Kutatási és Fejlesztési Igazgató / Director de cercetare și Dezvoltare

Fait à Meylan, le / Established in Meylan, on / Geschehen zu Meylan, am / En Meylan, a / Redatto a Meylan, / Vastgesteld te Meylan, / Uformat i Meylan, den / Meylan, Ranska, / Sporządzono w Meylan, dnia / Meylan, dnia / V Meylanu, / V Meylan dňa / Kelt Meylanban, / Întocmită la Meylan, pe data de 11/02/2021 - 02/11/2021



INSTALLATION AND SAFETY INSTRUCTIONS

TRANSLATION FROM THE ORIGINAL MANUAL

IMPORTANT : Before assembly and start-up, please read and clearly understand all the documents relating to this equipment (professional use only).

THE PICTURES AND DRAWINGS ARE NON CONTRACTUAL. WE RESERVE THE RIGHT TO MAKE CHANGES WITHOUT PRIOR NOTICE.

SAMES KREMLIN SAS
13, chemin de Malacher
38 240 - MEYLAN - France
☎ : 33 (0)4 76 41 60 60

www.sames-kremlin.com

1. SAFETY INSTRUCTIONS

GENERAL SAFETY INSTRUCTIONS



CAUTION : The equipment can be dangerous if you do not follow our instructions concerning installation and servicing described in this manual and in accordance with applicable European standards and local national safety regulations.

Please carefully read all the instruction literature before operating your equipment.

Only trained operators can use the equipment.

The foreman must ensure that the operator has understood the safety instructions for this equipment as well as the instructions in the manuals for the different parts and accessories.

Read carefully all instruction manuals, label markings before operating the equipment.

Incorrect use may result in injury. This equipment is for professional use only. It must be used only for what it has been designed for. Never modify the equipment. The parts and accessories supplied must be regularly inspected. Defective or worn parts must be replaced.

Guards (motor cover, coupling shields, connectors,...) have been designed for a safe use of the equipment.
The manufacturer will not be held responsible for bodily injury or failure and / or property damage due to destruction, the overshadowing or the partial or total removal of the guards.

Never exceed the equipment components' maximum working pressure.

Comply with regulations concerning safety, fire risks, electrical regulations in force in the country of final destination of the material. Use only products or solvent compatible with the parts in contact with the material (refer to data sheet of the material manufacturer).

PICTOGRAMS

A	D	F	E	C	G
NIP HAZARD	WARNING MOVING ELEVATOR	WARNING MOVING PARTS	WARNING MOVING SHOVEL	DO NOT EXCEED THIS PRESSURE	HIGH PRESSURE HAZARD
H	J	L	K	M	Q
RELIEF OR DRAIN VALVE	WARNING HOSE UNDER PRESSURE	WEAR GLASSES OBLIGATORY	WEAR OF GLOVES IS OBLIGATORY	PRODUCT VAPOR HAZARDS	WARNING HOT PARTS OR AREAS
N	P	R	S	T	U
ELECTRICAL HAZARD	WARNING FIRE HAZARDS	EXPLOSION HAZARDS	GROUNDING	WARNING (USER)	WARNING SERIOUS INJURIES

PRESSURE HAZARDS



Current legislation requires that an **air relief** valve be fitted in the air supply circuit to the air motor to prevent over pressurisation. This safety feature, ensures that it is not possible to supply the air motor with excessive air pressure that may cause injury.

Please ensure that a **material drain valve** is fitted in the fluid circuit to drain and depressurise the circuit. Once depressurised and drained, work /servicing may then commence on the equipment. Please remember to close these valves when restarting the system.

HIGH PRESSURE INJECTION HAZARDS



When working with high pressure equipment, special care is required. Fluid leaks can occur. There is a risk of material being injected to any exposed parts of body, this could cause severe injury :

- medical care must be sought immediately if paint is injected under the skin or in other parts of the body (eyes, fingers).
- never point the spray gun at any one. Never try to stop the spray with your hands or fingers nor with rags or similars.
- **follow the shut down procedure and always depressurize air and fluid circuits** before carrying out any servicing on the gun (cleaning, checking, maintenance of the material or cleaning of the gun nozzles).
- for the guns equipped with a safety device, always lock the trigger when not in use.

FIRE - EXPLOSION - SPARKS - STATIC ELECTRICITY HAZARDS



A poor earth connection, inadequate ventilation, sparks or static electricity can cause an explosion or fire. to avoid these risks when using or servicing SAMES KREMLIN equipment, the following safety procedures must be followed :

- ensure a good earth connection and ground the parts to be handled i.e. solvents, materials, components and equipment,
- ensure adequate ventilation,
- keep working area clean and free from waste solvents, chemicals, or solid waste i.e. rags, paper and empty chemicals drums,
- never use electrical switches / power if in an atmosphere of volatile solvent vapour,
- stop working immediately in case of electrical arcs,
- never store chemicals and solvents in the working area.
- use paint whose flash point is the highest possible to prevent from any formation of gas and inflammable vapours (refer to materials' safety instructions),
- install a cover on the drums to reduce the diffusion of gas and vapours in the spraybooth.

TOXIC PRODUCT HAZARDS



Toxic products or vapours can cause severe injury not only though contact with the body, but also if the products are ingested or inhaled. It is imperative :

- to know the material products and their risks,
- notified or hazardous materials must be stored in accordance with the regulations,
- the material must be stored in an appropriate container, never place materials in a container where there is a risk of spillage or leakage,
- a procedure must be applied for the safe disposal of waste material. It must comply with all prevailing regulations and legislations of the country where the equipment is to be used,
- protective clothing should always be worn in compliance with the material manufacturers' recommendations,
- depending on the application and chemical safety instructions, safety glasses, hearing protective earplug, gloves, foot wear, protective masks and possible breathing equipment should be worn to comply with the regulations (Refer to chapter "Safety equipment of SAMES KREMLIN selection guide).



CAUTION!

It is forbidden to use material containing high concentrations of halogenated hydrocarbon solvents with **aluminium** or **zinc fillers**. Non-compliance with the instructions may cause explosion risk causing serious or fatal injury.



EQUIPMENT REQUIREMENTS

Guards (motor cover, coupling shields, connectors,...) have been designed for a safe use of the equipment.
The manufacturer will not be held responsible for bodily injury or failure and / or property damage due to destruction, the overshadowing or the partial or total removal of the guards.



PUMP

Before carrying out any work, it is imperative to read and clearly understand the disassembly and reassembly instructions before servicing. The operator must understand the equipment and the safety instructions. These instructions are available in the equipment manuals.

The air motor is designed to be mounted with a pump. Never modify any components or couplings. When operating, please keep hands away from moving parts. Before starting up the equipment, please read the PRESSURE RELIEF instructions. Please ensure that any relief or drain valves fitted are in good working order.

HOSES

- Keep hoses out of circulation areas, moving parts or hot surfaces,
- Never expose product hoses to temperature higher than + 60°C / 140° F or lower than 0°C / 32° F,
- Never pull or use the hoses to move the equipment,
- Tighten all fittings as well as the hoses before operating the equipment,
- Check the hoses regularly; change them if they are damaged,
- Never exceed the maximum working pressure (MWP) indicated on the hose.

USED PRODUCTS

Considering the wide variety of products that are available and can be used in our equipment it is impossible to check and make recommendations for all chemical data, regarding the risks of possible chemical attack and their long term chemical reaction

SAMES KREMLIN can not be held liable for :

- compatibility of wetted parts,
- risks to staff and the surroundings,
- for worn or defective parts, for faulty equipment or units, or the quality of final product.

It is the responsibility of the user to know and prevent any possible risks such as toxic vapours, fires or explosions. He shall determine the risks of immediate reactions or pursuant to repeated exposures of the staff,

SAMES KREMLIN shall not be liable for physical injuries, direct or indirect material damages caused by the use of chemicals.

2. HANDLING

 **Check the weight and the dimensions of the equipment**
(☞ refer to 'Technical features' section of the instruction manual)

If weight and dimensions are too important, the unloading must be carried out by means of a forklift or any other appropriate means with a qualified personnel and in a clear horizontal area to prevent from risks of damage injury or an accident.

The centre of gravity is not in the centre of the machine : carry out by hand a stability-test after having lifted the whole at 10 cm / 3.937" maximum.

After the unloading, the handling of the whole (eg: elevator pump) is carried out by means of a pallet truck taking the bottom part of the frame.

Remark : Each pump motor is fitted with a ring. The ring is designed for the hoisting of one pump and can not be used for the handling of the complete assembly.

3. STORING

Storing before installation :

- Storing ambient temperature : 0 / +50 °C / 0 / +122°F
- Protect the whole against dust, water trickling, dampness and shocks.

Storing after installation :

- Operating temperature : +15 / +35 °C / +59 / +138.2° F
- Protect the whole against dust, water tricing, dampness and shocks.

4. INSTALLATION OF THE EQUIPMENT

The machine is installed on a stable horizontal floor (for eg a concrete flag).

The machine shall be made stable by the use of holding down bolts or by the use of other anchoring methods, strong enough to prevent unintended bodily movement of the equipment.



To avoid risks caused by static electricity, the equipment as well as its components must be grounded.

- **For the pumping equipments** (pumps, pneumatic rams, frame...), a section wire of 2.5 mm² is fixed on the material. Use this wire to connect the material to "the general ground". In case of severe environments (mechanical protection of the wire of earthing insufficient, vibrations, mobile material...) where function damages at the ground are probable, the user have to replace the provided wire of 2.5 mm² by a device more adapted to its environment (wire with a more important section, bonding strip, fixing by thimble with eyelet...).

The continuity of the ground must be controlled by a qualified electrician. If the continuity of the ground is not ensured, check the terminal, the wire and the earthing point. **Never** use the material without have solved this problem.

- In the severe cases of environments (mechanical protection of the wire of earthing insufficient, vibrations, mobile material...) where damages of the function put at the ground are probable, the user will have to replace the wire of 2.5 mm² provided, by a device more adapted to its environment (wire of more important section, bonding strip, fixing by thimble with eyelet...),
- **The gun** must be 'grounded' via a material hose or an air hose. In case of spraying by means of a gun with cup, the air hose must be conductive,
- **The materials to be painted** must also be grounded.

All the materials situated in the working area shall be grounded.



- **Never store** more than necessary inflammable materials inside the working area,
- The materials must be stored into **approved drums** and grounded,
- Use only grounded **metals containers** for the use of cleaning solvents,
- **Cardboard and paper are prohibited.**

5. MARKING OF THE EQUIPMENT

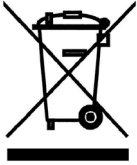

Each equipment has a label plate with the name of the manufacturer, the equipment part number, the interesting informations to use correctly the equipment (pressure, voltage,...) and sometimes the above pictogram.

The equipment is designed with and consists of high quality materials and components which can be re-used.

The 2012/19/UE European Directive covers all equipments with a crossed-out bin pictogram. Please inform yourself about the collection systems for electric and electronic equipments.

Please act in accordance with local rules and **do not dispose of old equipment with household wastes**. A correct disposal of old equipment will help prevent negative consequences for the environment and health.

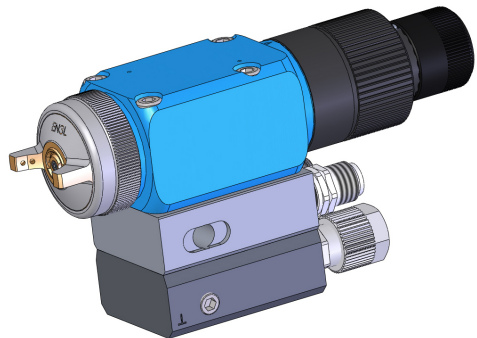
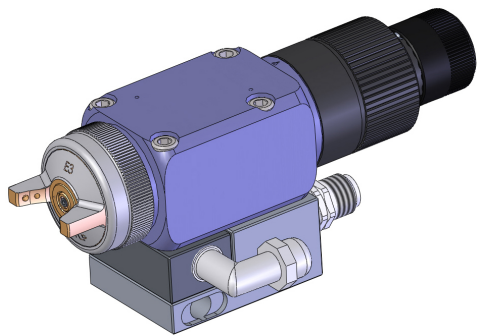

AUTOMATIC AIRSPRAY GUN

A 35

Disassembly / Reassembly

TRANSLATION FROM THE ORIGINAL MANUAL

IMPORTANT : Before assembly and start-up, please read and clearly understand all the documents relating to the equipment (professional use only).

THE PICTURES AND DRAWINGS ARE NOT CONTRACTUAL. WE RESERVE THE RIGHT TO MAKE CHANGES WITHOUT PRIOR NOTICE.

SAMES KREMLIN SAS
13, chemin de Malacher
38 240 - MEYLAN - France
☎ : 33 (0)4 76 41 60 60

www.sames-kremlin.com



CAUTION :

Before any intervention on the gun, shut off the compressed air supply and depressurize the circuits controlling the opening of the gun.

The gun is manufactured under the ATEX agreement and can not be modified. SAMES KREMLIN will not be held responsible for any failure to comply with that instruction.

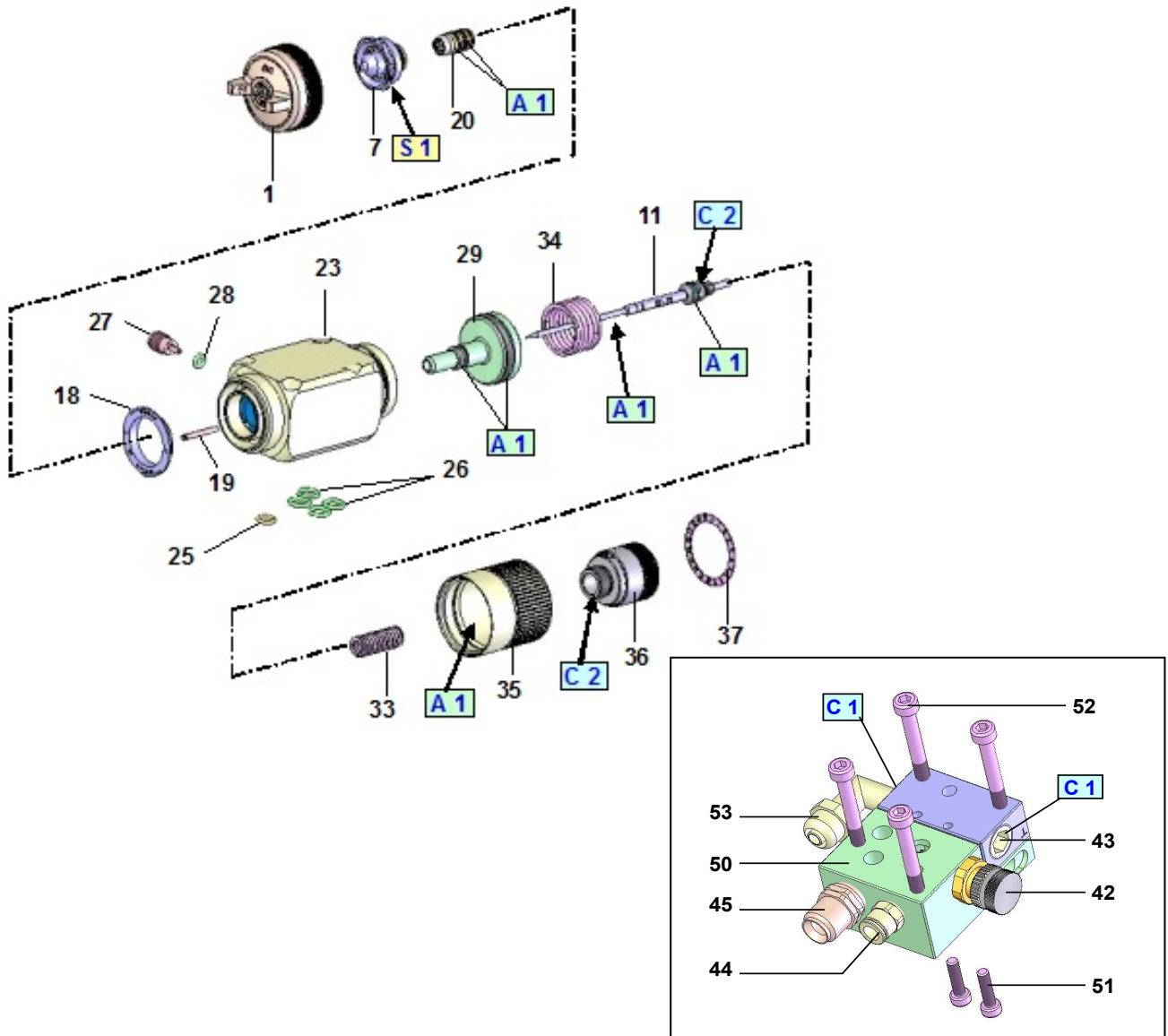

Index	Instructions	Description	Part number
A 1	PTFE grease	'TECHNILUB' grease (10 ml)	560.440.101
C 1	Medium strength Aneorobic Pipe sealant	Loctite 577 (250 ml)	544.180.015
C 2	Low strength - Aneorobic Adhesive	Loctite 222 (50 ml)	544.180.010
S 1	Screwing torque : 18 Nm / 13.3 ft/lbs		

Before removing a component of the gun, some precautions have to be taken :

- Empty out the paint inside the cup or the receiver.
- Fill the cup or the receiver with cleaning solvent.
- Decrease the supply air pressure of the gun.
- Spray the solvent until it runs clear.
- Shut off the supply air pressure of the gun.
- Trigger the gun to depressurize the circuit.
- Empty out the solvent when using a gravity cup.
- Remove the part to be cleaned or changed.

Before reassembling the different components, some precautions must be taken :

- **Clean all the parts with the appropriate cleaning solvent and a brush.**
- **Install new seals if it is necessary after having lubricated them with PTFE grease.**
- **Install new parts if it is necessary.**

▪ **CHANGING THE GUN**

Shut off the air and material supplies of the gun. Depressurize the circuits.

Separate the gun from its base unscrewing the 4 screws.

Install the new gun on its base changing the seals (25 and 26) and reinstall the 4 screws.

▪ **CARTRIDGE AND NEEDLE**

Unscrew the cylinder (35) - (pay attention to the springs 33 and 34).

Hold the needle and piston assembly (11 and 29) and pull it backwards.

Put aside the aircap (1) and the nozzle (7).

Unscrew the screw (27) by 2 turns (leakage detector).

Introduce one of the screws (52 or 59) backwards instead of the needle and force or knock until the cartridge (20) gets out frontwards.

Clean carefully with solvent and blow with air.

Change the seals. Install new ones.

Introduce the new cartridge frontwards.

🔁 **IMPORTANT : with the head screw (52 or 59), push the cartridge completely. Knock slightly on it if necessary.**

Tighten the leakage detector (27).

Reinstall the piston and needle assembly (29 and 11).

Install the springs (33 and 34).

Screw the cylinder (35).

Unscrew the needle stop (36); then, reinstall the nozzle (7) and the aircap (1).



During the assembly of the gun, screw completely the indexed needle and check the lining up of the 3 following elements : the mark done on the body, the 0 on the indexing ring and the line on the stop.

If it not be so, unclip the disc located on the indexed stop and change it alining up the line with the 0.

Doc. 573.366.050

Date/Datum/Fecha : 20/02/18

Annule/Cancel/Ersetzt/Anula :
25/07/13

Modif. / Änderung :

Mise à jour / Update / Aktualisierung
/ Actualización

+ Ind. / Pos. 35 → Ind. / Pos. 50

+ Ind. / Pos. 36 → Ind. / Pos. 51

Pièces de rechange

Spare parts list

Ersatzteilliste

Piezas de repuesto

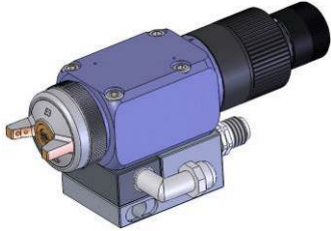

A 35

**PISTOLET PNEUMATIQUE AVEC EMBASE
AIRSPRAY GUN WITH BASE
PNEUMATISCHE PISTOLE MIT GRUNDPLATTE
PISTOLA NEUMÁTICA CON BASE**

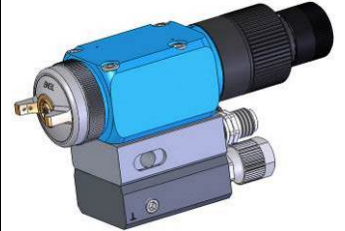

A 35 HTi - A 35 HPA

A 35 HTi : Pistolet à haut taux de transfert / Gun with high transfer efficiency
Pistole mit ausgezeichneter Übertragungsrage / Pistola con alta tasa de transfer

A 35 HPA : Pistolet à haut pouvoir d'atomisation / Gun with high spraying quality
Pistole mit hoher Zerstäubungsqualität / Pistola con alto poder de atomización

**A 35 HTi / A 35 HPA
MOD. 1 (A + B1)**

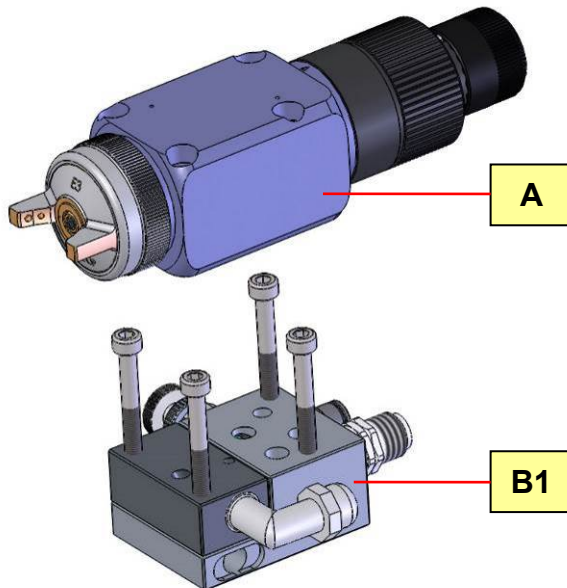

**A 35 HTi / A 35 HPA
MOD. 2 (A + B2)**

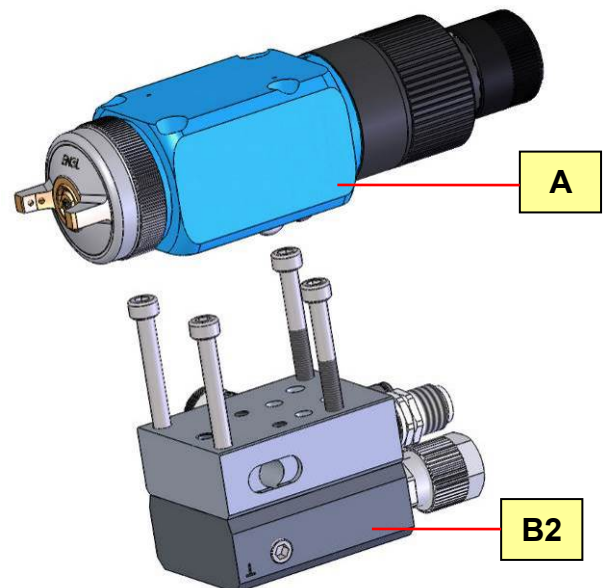

A : Pistolet sans embase / Gun without base / Pistole ohne Grundplatte / Pistola sin base

B1 / B2 : Embase / Base / Grundplatte / Base

B 1 : raccordements produit latéraux / lateral fluid connections
Materialanschlüsse seitlich / conexiones producto laterales

B 2 : raccordements produit arrière / back fluid connections
Materialanschlüsse hinten / conexiones producto trasero

PISTOLET / GUN / PISTOLE / PISTOLA : A 35

A35 avec embase / with base / mit Grundplatte / con base

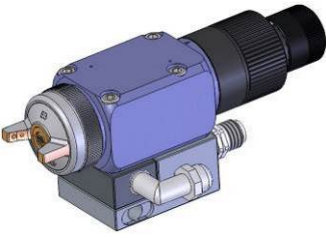
A 35 HTi (KHVLP)	#	A 35 HTi	#	A 35 HPA	#	A + B1 
+ 06 E3 KHVLP	135 300 112	+ 06 EP 3	135 300 111	+ 06 EN 3L	135 305 106	
+ 07 E3 KHVLP	135 300 101	+ 07 EP 3	135 300 106	+ 07 EN 3L	135 305 101	
+ 09 E3 KHVLP	135 300 102	+ 09 EP 3	135 300 107	+ 09 EN 3L	135 305 102	
+ 12 E3 KHVLP	135 300 103	+ 12 EP 3	135 300 108	+ 12 EN 3L	135 305 103	
+ 15 E3 KHVLP	135 300 104	+ 15 EP 3	135 300 109	+ 15 EN 3L	135 305 104	
+ 18 E3 KHVLP	135 300 105	+ 18 EP 3	135 300 110	+ 18 EN 3L	135 305 105	

A 35 HTi (KHVLP)	#	A 35 HTi	#	A 35 HPA	#	A + B2 
+ 06 E3 KHVLP	135 300 212	+ 06 EP 3	135 300 211	+ 06 EN 3L	135 305 206	
+ 07 E3 KHVLP	135 300 201	+ 07 EP 3	135 300 206	+ 07 EN 3L	135 305 201	
+ 09 E3 KHVLP	135 300 202	+ 09 EP 3	135 300 207	+ 09 EN 3L	135 305 202	
+ 12 E3 KHVLP	135 300 203	+ 12 EP 3	135 300 208	+ 12 EN 3L	135 305 203	
+ 15 E3 KHVLP	135 300 204	+ 15 EP 3	135 300 209	+ 15 EN 3L	135 305 204	
+ 18 E3 KHVLP	135 300 205	+ 18 EP 3	135 300 210	+ 18 EN 3L	135 305 205	

A35 sans embase / without base / ohne Grundplatte / sin base

A 35 HTi (KHVLP)	#	A 35 HTi	#	A 35 HPA	#	A 
(☐)	129 300 000	(☐)	129 300 000	(☐)	129 305 000	
+ 06 E3 KHVLP	135 300 012	+ 06 EP 3	135 300 011	+ 06 EN 3L	135 305 006	
+ 07 E3 KHVLP	135 300 001	+ 07 EP 3	135 300 006	+ 07 EN 3L	135 305 001	
+ 09 E3 KHVLP	135 300 002	+ 09 EP 3	135 300 007	+ 09 EN 3L	135 305 002	
+ 12 E3 KHVLP	135 300 003	+ 12 EP 3	135 300 008	+ 12 EN 3L	135 305 003	
+ 15 E3 KHVLP	135 300 004	+ 15 EP 3	135 300 009	+ 15 EN 3L	135 305 004	
+ 18 E3 KHVLP	135 300 005	+ 18 EP 3	135 300 010	+ 18 EN 3L	135 305 005	

(☐) : *Pistolet sans projecteur, sans embase / Gun without projector, without base
Pistole ohne Zerstäubereinheit, ohne Grundplatte / Pistola sin proyector, sin base*

Projecteur / Projector / Zerstäubereinheiten / Proyector (Ind. 1+7+11)					
Ind. 1+7+11	#	Ind. 1+7+11	#	Ind. 1+7+11	#
06 E3 K HVLP	031 300 012	06 EP 3	031 300 011	06 EN 3L	031 305 006
07 E3 K HVLP	031 300 001	07 EP 3	031 300 006	07 EN 3L	031 305 001
09 E3 K HVLP	031 300 002	09 EP 3	031 300 007	09 EN 3L	031 305 002
12 E3 K HVLP	031 300 003	12 EP 3	031 300 008	12 EN 3L	031 305 003
15 E3 K HVLP	031 300 004	15 EP 3	031 300 009	15 EN 3L	031 305 004
18 E3 K HVLP	031 300 005	18 EP 3	031 300 010	18 EN 3L	031 305 005

Tête / Aircap Luftkappe / Cabezal	
Ind. 1	#
E 3 K HVLP	132 300 100
EP 3	132 300 300
EN 3L	132 305 200

Buse / Nozzle / Düse / Boquilla			Pointeau / Needle / Nadel / Aguja	
Ind. 7	Ø (mm / ")	#	Ind. 11	#
06	0,6 / 0.023	134 130 050	06 - 07 - 09 - 12	033 300 100
07	0,7 / 0.028	134 130 100		
09	0,9 / 0.035	134 130 200		
12	1,2 / 0.047	134 130 300		
15	1,5 / 0.059	134 130 600	15 - 18	033 300 200
18	1,8 / 0.071	134 130 700		

A **PISTOLET / GUN / PISTOLE / PISTOLA**
(inox / stainless steel / Edelstahl)

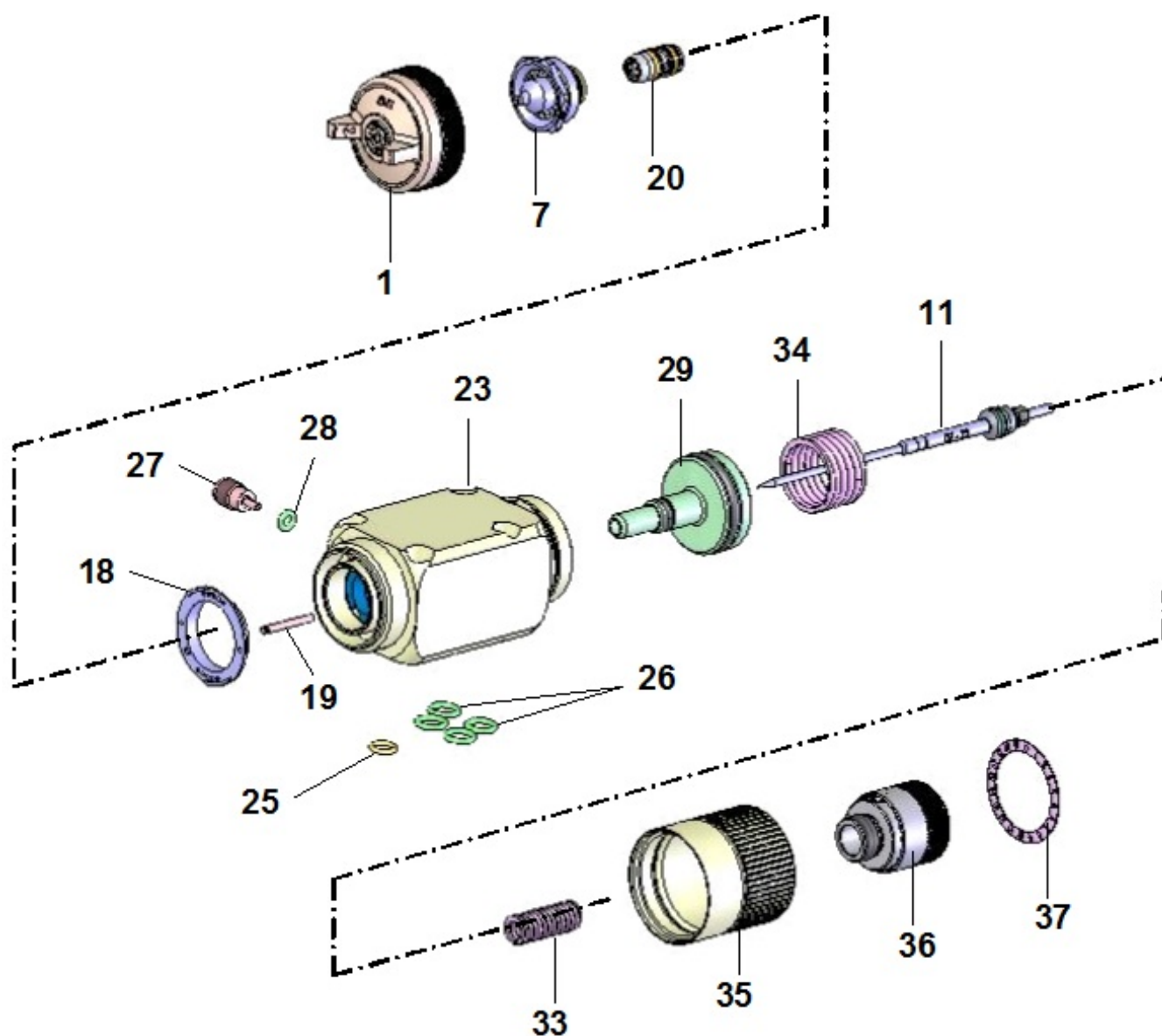

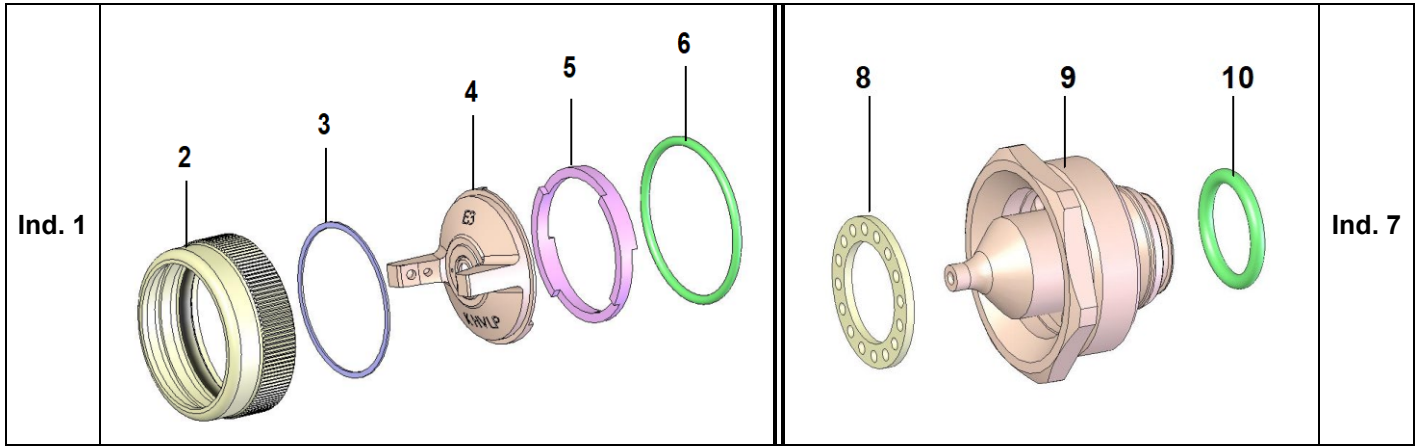

Ind	#	Désignation	Description	Bezeichnung	Denominación	Qté
*1	-	Tête indexée complète (voir tableau)	Indexed aircap assembly (refer to chart)	Zerstäuberkopf kpl. mit Indexierungsring (siehe Tabelle)	Cabezal completo indexado (consultar cuadro)	1
2	029 130 005	• Bague de tête	• Aircap ring	• Haltering	• Anillo de cabezal	1
3	129 080 007	• Joint de tête (les 2)	• Aircap seal (pack of 2)	• O-Ring (10 St.)	• Junta de cabezal (x 2)	1
4	NC / NS	• Tête nue	• Aircap only	• Luftkappe	• Cabezal solo	1
5	032 300 102	• Anneau d'indexage	• Index ring	• Indexierungsring	• Anillo de indexación	1
6	150 040 309	• Joint de bague (les 10)	• Ring seal (pack of 10)	• O-Ring (10 St.)	• Junta de anillo (x 10)	1
*7	-	Buse équipée (voir tableau)	Nozzle assembly (refer to chart)	Düse kpl. (siehe Tabelle)	Boquilla equipada (consultar cuadro)	1
8	129 130 004	• Bague de répartition (les 5)	• Distribution ring (pack of 5)	• Luftverteilerring (5 St.)	• Anillo de distribución (bolsa de 5)	1
9	NC / NS	• Buse	• Nozzle	• Düse	• Boquilla	1
10	129 209 902	• Joint de buse (les 5)	• Nozzle seal (pack of 5)	• O-Ring, Düse (5 St.)	• Junta de boquilla (x 5)	1

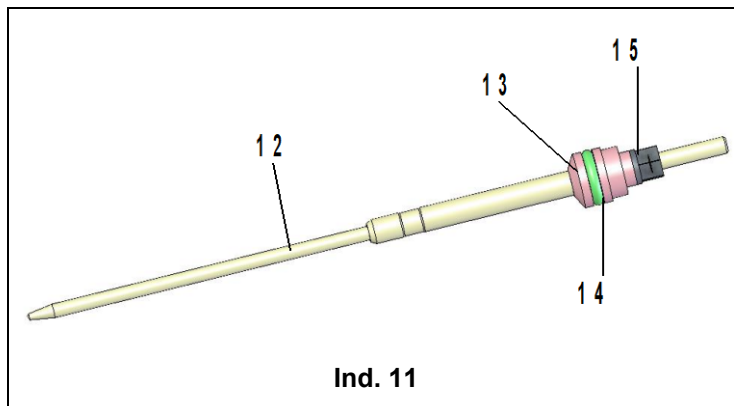

*11	-	Pointeau équipé (voir tableau)	Needle assembly (refer to chart)	Farbnadel kpt (siehe Tabelle)	Aguja equipada (consultar cuadro)	1
12	NC / NS	• Pointeau	• Needle	• Nadel	• Aguja	1
13	029 251 301	• Entraîneur de pointeau	• Needle retainer	• Nadelmitnehmer	• Arrastre de aguja	1
14	129 400 915	• Joint FPM (les 10)	• FPM O-Ring (x 10)	• O-Ring, FPM (10 St.)	• Junta FPM (x 10)	1
15	029 251 303	• Ecrou special	• Special nut	• Spezialmutter	• Tuerca especial	1

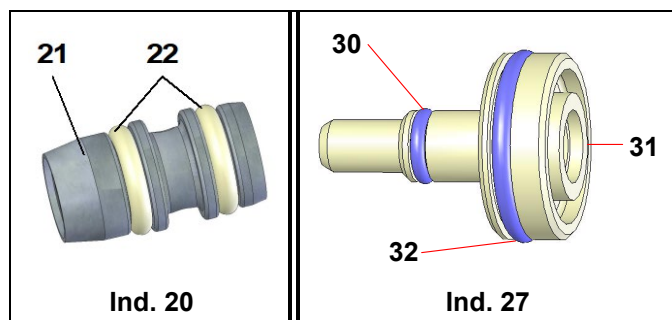

Ind	#	Désignation	Description	Bezeichnung	Denominación	Qté
18	129 300 025	Bague de répartition d'air (les 5)	Air distribution ring (pack of 5)	Luftverteilerring (5 St.)	Anillo de distribución de aire (bolsa de 5)	1
19	029 300 026	Goupille	Pin	Stift	Pasador	1
*20	129 690 039	Cartouche complète	Cartridge assembly	Nadelpackung, kpl.	Cartucho completo	1
21	NC / NS	• Cartouche	• Cartridge	• Nadelpackung	• Cartucho	1
22	909 429 702	• Joint blanc (polyfluid)	• White seal, Polyfluid	• O-Ring, weiß, Polyfluid	• Junta blanca, Polifluido	2
23	NC / NS	Corps A35 HTi	Body, model A35 HTi	Pistolenkörper, A35 HTi	Cuerpo A35 HTi	1
-	NC / NS	Corps A35 HPA	Body, model A35 HPA	Pistolenkörper, A35 HPA	Cuerpo A35 HPA	1
25	150 040 328	Joint torique (les 10)	O-Ring (pack of 10)	O-Ring (10 St.)	Junta tórica (bolsa de 10)	1
26	129 251 991	Joint torique (les 10)	O-Ring (pack of 10)	O-Ring (10 St.)	Junta tórica (bolsa de 10)	4
27	029 690 001	Témoin de fuite	Detector, fluid leakage	Leckageanzeige	Testigo de fuga	1
28	129 529 903	Joint (les 10)	Seal (x 10)	Dichtung (10 St.)	Junta (bolsa de 10)	1
*29	129 690 010	Piston équipé	Piston assembly	Kolben, kpl.	Pistón equipado	1
30	129 479 910	• Joint R6 (les 10)	• Seal, model R6 (x 10)	• O-Ring, R6 (10 St.)	• Junta R6 (bolsa de 10)	1
31	NC / NS	• Piston seul	• Piston only	• Kolben, nackt	• Pistón solo	1
32	909 130 522	• Joint noir R20	• Black seal, model R20	O-Ring, schwarz, R20	• Junta negra R20	1
*33	050 312 226	Ressort de pointeau (inox)	Needle spring (stainless steel)	Feder für Farbnadel (Edelstahl)	Muelle de aguja (inox)	1
*34	050 313 504	Ressort de piston	Piston spring	Feder für Kolben	Muelle de pistón	1
35	029 690 041	Cylindre	Cylinder	Luftzylinder	Cilindro	1
36	129 300 020	Equipement d'indexage	Index equipment	Indexierter Nadelanschlag	Equipo de indexación	1
37	149 022 012	Cadran d'indexage	Index dial	Indexierte Skalenscheibe	Disco de indexación	1

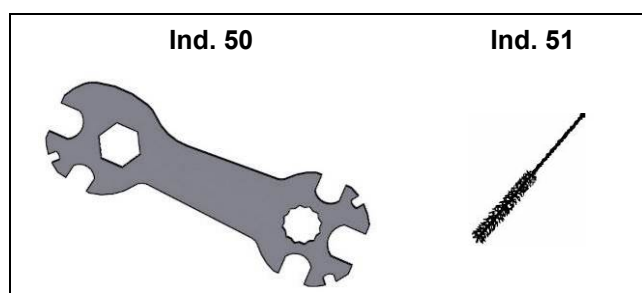

Ind	#	Désignation	Description	Bezeichnung	Denominación	Qté
50	049 030 042	Clé plate	Gun wrench	Pistolenschlüssel	Llave para pistola	1
51	906 300 101	Goupillon	Large size brush	Pistolenreinigungsbürste	Cepillo grande	1

POCHETTES - KITS - SÄTZE - BOLSAS

Ind	#	Désignation	Description	Bezeichnung	Denominación	Qté
*	129 300 901	Pochette de joints (ind. 3, 6, 10, 14, 22x2, 25, 26x4, 28, 30, 32, 43, 44, 45 + tube de graisse)	Package of seals (ind. 3, 6, 10, 14, 22x2, 25, 26x4, 28, 30, 32, 43, 44, 45 + grease tube)	Dichtungssatz (Pos. 3, 6, 10, 14, 22x2, 25, 26x4, 28, 30, 32, 43, 44, 45 + tube-fett)	Bolsa de juntas (ind. 3, 6, 10, 14, 22x2, 25, 26x4, 28, 30, 32, 43, 44, 45 + tubo de grasa)	1

* Pièces de maintenance préconisées.

* Preceding the index number denotes a suggested spare part.

* Bezeichnete Teile sind empfohlene Ersatzteile.

* Piezas de mantenimiento preventivas.

N C : Non commercialisé.

N S : Denotes parts are not serviceable separately.

N S : bezeichnete Teile gibt es nicht einzeln, sondern nur komplett.

N C : no suministrado.

B

EMBASES - BASES - GRUNDPLATTEN - BASES (insert inox / stainless steel insert / Edelstahl-Einsatz / Inserto inox)

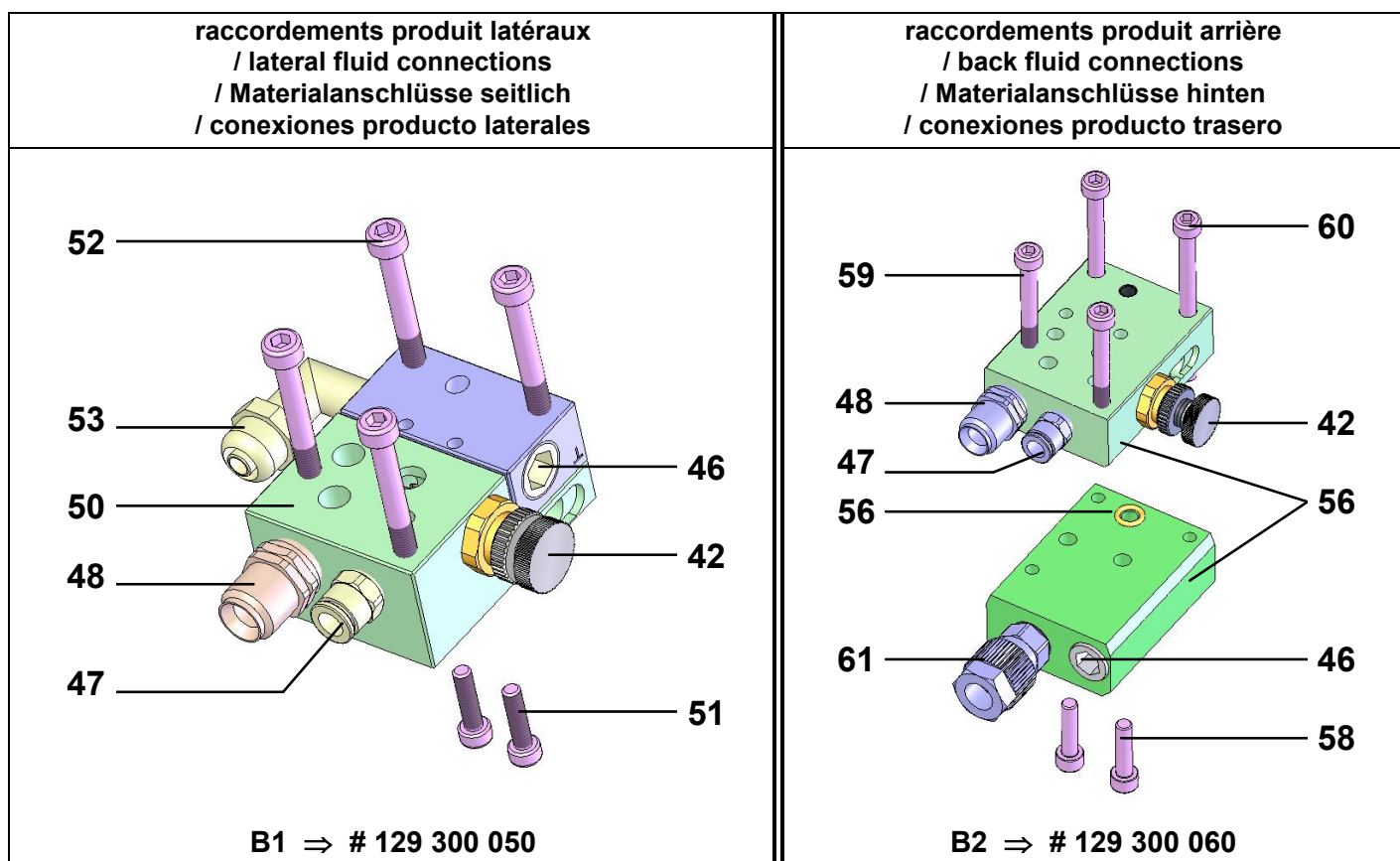

Pièces communes - Common parts - Gleiche Teile - Partes comunes

Ind	#	Désignation	Description	Bezeichnung	Denominación	Qté
42	129 253 100	Pointeau des évènements	Air adjuster	Spritzstrahlregulierschraube	Aguja control abanico	1
43	129 529 907	• Joint FPM (les 10)	• FPM O-Ring (x 10)	• O-Ring, FPM (10 St.)	• Junta FPM (x 10)	1
44	129 400 915	• Joint FPM (les 10)	• FPM O-Ring (x 10)	• O-Ring, FPM (10 St.)	• Junta FPM (x 10)	1
45	102 202 101	• Circlips Ø 5 (les 10)	• Ring, Ø 5 (x 10)	• Sicherungsring (10 St.)	• Anillo truarc Ø 5 (x 10)	1
46	905 210 303	Bouchon type 1/4" (inox)	Plug, model 1/4" (stainless steel)	Blindstopfen, 1/4" (Edelstahl)	Tapón, tipo 1/4" (inox)	1

Ind	#	Désignation	Description	Bezeichnung	Denominación	Qté
47	905 124 901	Raccord (commande), type M 1/8 BSP - T 4 x 6	Quick release fitting (control), model M1/8 BSP- T4 x 6	Stecknippel (Steuerluft), AG 1/8 BSP – Schlauch 4 x 6	Racor (mando), tipo M 1/8 BSP tubería 4 x 6	1
48	050 102 624	Raccord (air) M 1/4 BSP - M 1/4 NPS	Fitting (air), model double male, 1/4 BSP - 1/4 NPS	Doppelnippel (Zerst.-Luft), AG 1/4 BSP - 1/4 NPS	Racor (aire), tipo M 1/4 BSP - M 1/4 NPS	1

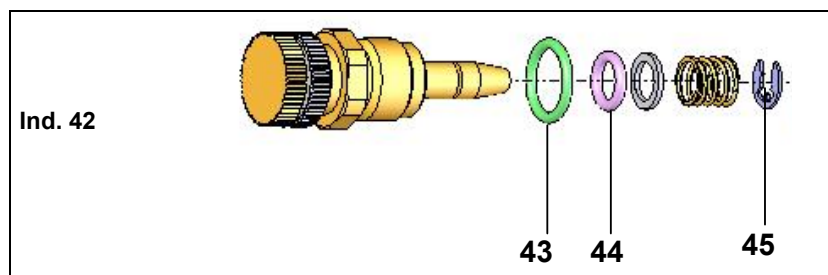

Pièces spécifiques - Specific parts - Spezifische Teile - Partes específicas

Pour embase / For base / Für Grundplatte B1 / Para base : # 129 300 050

Ind	#	Désignation	Description	Bezeichnung	Denominación	Qté
50	NC / NS	Embase + insert	Base + insert	Grundplatte + ES Einsatz	Base + inserto	1
51	933 151 219	Vis M 4 x 16	Screw, model M 4 x 16	Schraube M4 x 16	Tornillo, tipo M 4 x 16	2
52	88 126	Vis M 5 x 40	Screw, model M 5 x 40	Schraube M 5 x 40	Tornillo, tipo M 5 x 40	4
53	905 190 401	Raccord coudé (produit) M 1/4" - T 6 x 8	Elbow (material) M 1/4" - hose 6 x 8	Winkelnippel (Material) AG1/4" - Schlauch 6 x 8	Codo (producto) M 1/4" - T 6 x 8	2

Pour embase / For base / Für Grundplatte B2 / Para base : # 129 300 060

Ind	#	Désignation	Description	Bezeichnung	Denominación	Qté
55	NC / NS	Embases	Bases	Grundplatten	Bases	1
56	150 040 328	Joint (les 10)	Seal (pack of 10)	Dichtung (10 St.)	Junta (bolsa de 10)	1
57	050 261 103	Bouchon	Plug	Blindstopfen	Tapón	1
58	933 151 275	Vis M 5 x 20	Screw, model M 5 x 20	Schraube M 5 x 20	Tornillo, tipo M 5 x 20	2
59	88 126	Vis M 5 x 40	Screw, model M 5 x 40	Schraube M 5 x 40	Tornillo, tipo M 5 x 40	2
60	930 151 596	Vis M 5 x 60	Screw, model M 5 x 60	Schraube M 5 x 60	Tornillo, tipo M 5 x 60	2
61	905 190 417	Raccord droit (produit) M 1/4" - T 6 x 8	Straight fitting (material) M 1/4" - hose 6 x 8	Gerader Nippel (Material) AG 1/4" - Schlauch 6 x 8	Racor recto (producto) M 1/4" - tubería 6 x 8	2

ACCESSOIRES - ACCESSORIES - ZUBEHÖR - ACCESORIOS

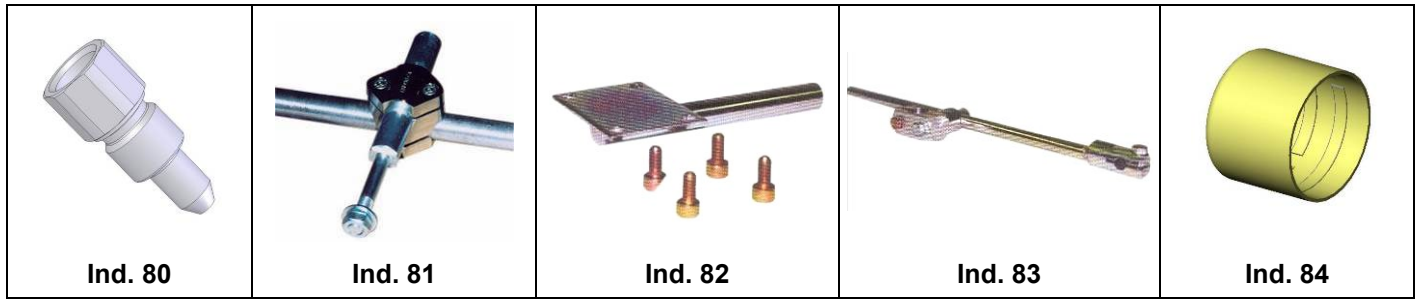

Ind	#	Désignation	Description	Bezeichnung	Denominación	Qté
80	029 253 002	Raccord pour réglage largeur de jet à distance	Remote adjusting fan width	Spezialanschluss zur Fernverstellung der Spritzstrahlbreite	Racor para ajuste anchura abanico a distancia	1
81	049 351 000	Support de fixation pour pistolet (Ø 16 mm longueur : 100 mm)	Mounting rod for gun (Ø 16 mm - 5/8" length : 100 mm / 4")	Pistolenhalterung (Ø 16 mm Länge: 100 mm)	Soporte de fijación para pistola (Ø 16 mm longitud : 100 mm)	1
82	049 351 700	Support de fixation	Mounting support	Halterung	Soporte de fijación	1
83	049 351 705	Support de fixation orientable	Swivelling mounting support	Halterung, orientierbar	Soporte de fijación orientable	1
84	106 380 856	Capac de protection pour pistolet (pochette de 10)	Protective cap for gun (pack of 10)	Schutzkappe für Pistolenkopf (10 St.)	Capa de protección para pistola (bolsa de 10)	1



AUTOMATIC AIRSPRAY GUN

PREVENTIVE MAINTENANCE

TRANSLATION FROM THE ORIGINAL MANUAL

IMPORTANT : Before assembly and start-up, please read and clearly understand all the documents relating to this equipment (professional use only).

THE PICTURES AND DRAWINGS ARE NON CONTRACTUAL. WE RESERVE THE RIGHT TO MAKE CHANGES WITHOUT PRIOR NOTICE.

SAMES KREMLIN SAS
13, chemin de Malacher
38 240 - MEYLAN - France
☎ : 33 (0)4 76 41 60 60

www.sames-kremlin.com

The gun is a precision instrument and it relies on good and frequent maintenance for its correct operation. If stopped for a long time, lubricate all movable parts, axes and springs with grease.

Never use metal brushes files, points or clips for dismantling.

▪ **SHORT DURATION SHUTDOWN**

Remove the paint on the air cap, with a brush and solvent. Otherwise, leave the equipment as it is. Removing the paint will prevent the drying and clogging of the holes.

▪ **LONG DURATION SHUTDOWN**

Shut off the gun fluid and air supply.

Depressurize the hoses by triggering the gun or by controlling the gun opening.

Unscrew the air cap. Remove the needle and then remove the fluid nozzle with the wrench provided. Soak the needle, aircap, fluid nozzle in solvent and brush them carefully, as they are precision parts.

With a brush soaked in solvent, clean the internal parts of the gun. Wash carefully brush the threaded parts.

Flush the gun.

Do not soak the gun in solvent



AUTOMATIC AIRSPRAY GUN

TROUBLESHOOTING GUIDE

TRANSLATION FROM THE ORIGINAL MANUAL

IMPORTANT : Before assembly and start-up, please read and clearly understand all the documents relating to the equipment (professional use only).

THE PICTURES AND DRAWINGS ARE NOT CONTRACTUAL. WE RESERVE THE RIGHT TO MAKE CHANGES WITHOUT PRIOR NOTICE.

SAMES KREMLIN SAS
13, chemin de Malacher
38 240 - MEYLAN - France
☎ : 33 (0)4 76 41 60 60

www.sames-kremlin.com

▪ **DISTORDED SPRAY**

Slightly unscrew the aircap retaining ring and rotate the aircap by one half turn. If the defect is reversed, one of the lateral air holes is plugged up or deformed. Clean the gun aircap with solvent and unclog the air holes with a compressed air. If the defect is not reversed, it means that the fluid nozzle is damaged.

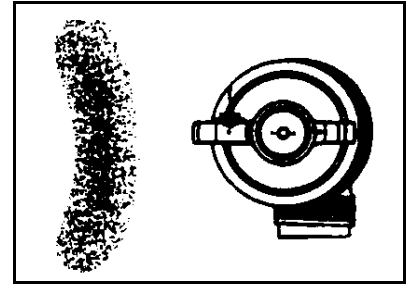

▪ **DISPLACED SPRAY**

This comes from a defect in the central fan. Clean the aircap and the fluid nozzle. Make sure that :

- the aircap is correctly centered on the nozzle,
- the nozzle is not too big for the needle,
- when work is done with a large needle opening and the needle almost closed, the spray pattern is not even in all directions.

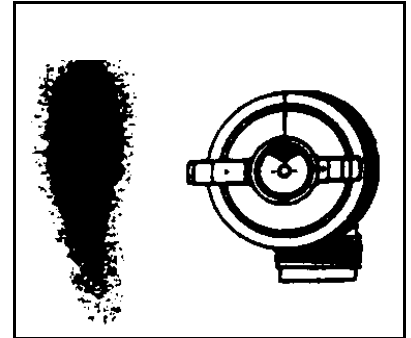

▪ **FRAGMENTED PATTERN**

The fan air pressure is too big at the holes in the air cap horns :

- turn the fan air control clockwise to reduce the fan air pressure.
- increase the paint output.

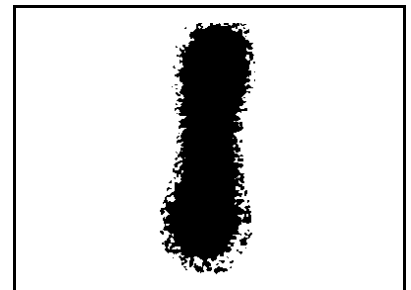

▪ **FAN TOO THICK IN THE CENTER**

This is the reverse of the above defect :

- the paint output is too high for the selected air pressure :
increase the spraying air pressure and reduce the paint output.
- if the paint is too thick, dilute it.

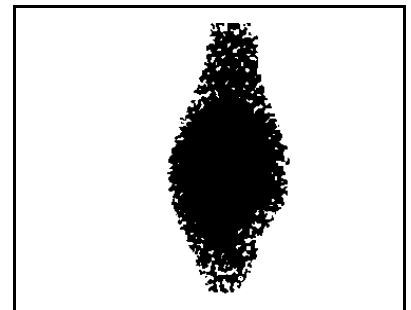

▪ **INTERMITTANT SPRAY PATTERN**

An air inlet in the paint circuit creates an intermittant pattern when :

- the paint cup is nearly empty,
- when the nozzle is not tightened on its seat : clamp it.

If the problem persists, remove the nozzle and clean it. Check that the seat and the cone are not damaged, remount the nozzle and clamp it.

When using a cup, air can get into the paint circuit :

through the passage seal of the needle into the gun body \Rightarrow tighten it.

through various fittings between the gun and the cup if these are not correctly tightened.

Check that : the cup cover air hole is not blocked and the paint is homogeneous and fluid enough (use the viscosity cup).

PROBLEM	CAUSE	SOLUTION
No fluid out of the gun	Tip is blocked	Relieve pressure on pump. Carefully remove spray tip and filter. Take care with residual pressure in the hoses.
Pattern width narrows during reversing phase of pump	Air trapped in the fluid circuit	Check connections and suction hose quality.
	Viscosity too high	Reduce viscosity.
Aircap becomes dirty frequently	Too much air	Reduce air pressure.
	Leak from fluid packing (or cartridge)	Replace packing or cartridge.
Fluid seeping from the air holes of the aircap	Defective tip seal	Replace it.
	Tip loose	Tighten it.
Fluid leak	Impurities in the paint	Trigger the gun 3 or 4 times.
	Needle worn	Remove the needle and the nozzle.
	Cartridge or packing worn	Replace.



AUTOMATIC AIRSPRAY GUN

OPERATING, CONTROL AND HANDLING

TRANSLATION FROM THE ORIGINAL MANUAL

IMPORTANT : Before assembly and start-up, please read and clearly understand all the documents relating to this equipment (professional use only).

THE PICTURES AND DRAWINGS ARE NON CONTRACTUAL. WE RESERVE THE RIGHT TO MAKE CHANGES WITHOUT PRIOR NOTICE.

SAMES KREMLIN SAS
13, chemin de Malacher
38 240 - MEYLAN - France
☎ : 33 (0)4 76 41 60 60

www.sames-kremlin.com

1. OPERATING



Safety instructions :

- Never try to stop the spray fan with any part of the body (hands, fingers...) or with rags. Never point the spray gun at anyone or at any part of the body.
- The operator will need medical attention if the high pressure material spray is in contact with the the body (eyes, fingers...).
- **Always lock the gun trigger with the safety device when not operating the gun.**
- **Always depressurize air and hoses** before carrying out any servicing on the gun.



In order to protect the operator, protective clothing (gloves, respirator mask, glasses, hearing protective earplug, clothes...) are required.
Use the equipment in a properly ventilated area.

Unscrew the needle adjustment knob at the back of the gun.

Unscrew the air adjuster (s) located on the base or on the gun.

Select the desired projector (aircap + nozzle + needle) best suited for the job at hand.

Screw on the nozzle, then the aircap to the gun.

Before tightening up firmly the aircap ring, position the aircap for the best spray. The fan is vertical when the 2 ears of the aircap are horizontal.

☞ **We advice you to put the gun in the "OPEN" position to prevent any damage to the needle while fitting the nozzle.**

2. CONTROL

This professional spray gun features 3 controls :

▪ THE AIR PRESSURE

- Supply the air of the network (clean air - maximum pressure : 6 bar / 87 psi) to the gun.
- Control the gun opening (air pressure > 3 bar / 43.5 psi).
- Adjust the air pressure upstream of the gun to obtain a correct spraying.

▪ THE FAN WIDTH

Can be adjusted by using the knurled knob. It controls the air going to the horns on the aircap. In this way, the air is controlled through the fanned air outlets and allows the fan to change from flat (wide open) to round (closed).

▪ THE FLUID OUTPUT

Having selected the proper fluid nozzle / needle assembly and the fluid pressure, it is possible to further control the output by changing the travel of the needle (needle stop knob) in case of fluid supply.

Optimal set-up is usually obtained when the product needle is completely open. When this needle is nearly closed, a regular flow of product can not be guaranteed.

3. GUN HANDLING

When mounting the aircap on the gun, hold it vertically in order to correctly adjust the aircap before screwing the aircap ring.

Keep the gun perpendicular to the surface to be painted. Avoid working with the wrist.

Do not forget that crossed sweeps cannot correct irregularities.

Spraying from a stationary gun will not give even coverage.

Make sure that overlapping from the passes is even (gun moving vertically, part moving horizontally).

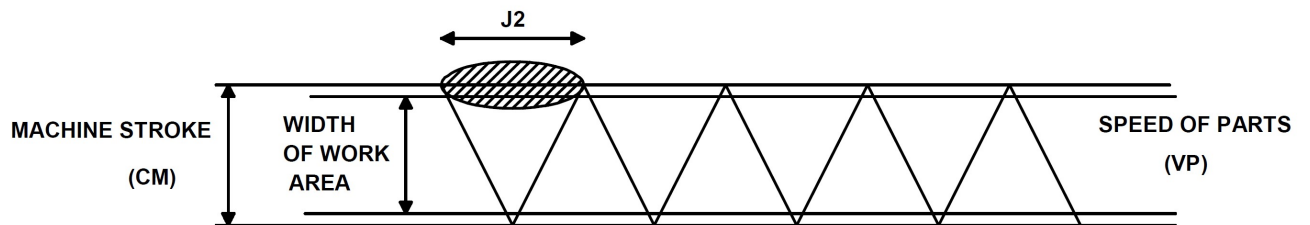

This width J2 for 2 regular coats of paint corresponds exactly to the following formula :

$$J 2 \text{ (m)} = VP \text{ (m/s)} \times 2 \frac{CM \text{ (m)}}{VM \text{ (m/s)}}$$

Where :

VP = speed of travel of the parts to be painted.

CM = total stroke of the machine (and therefore of the spray guns).

VM = speed of the machine (and therefore of the spray guns).

2 = 2 regular coats of paint (or 4 if you want to double the number of coats).

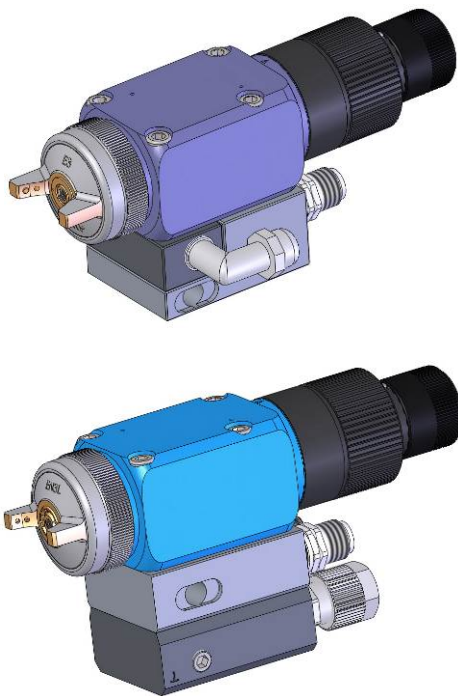

AUTOMATIC AIRSPRAY GUN

A 35

TECHNICAL FEATURES

TRANSLATION FROM THE ORIGINAL MANUAL

IMPORTANT : Before assembly and start-up, please read and clearly understand all the documents relating to the equipment (professional use only).

THE PICTURES AND DRAWINGS ARE NOT CONTRACTUAL. WE RESERVE THE RIGHT TO MAKE CHANGES WITHOUT PRIOR NOTICE.

SAMES KREMLIN SAS
13, chemin de Malacher
38 240 - MEYLAN - France
☎ : 33 (0)4 76 41 60 60
www.sames-kremlin.com

1. DESCRIPTION

The A35 gun is designed for the spraying of paints, lacquers, adhesives in automatic installations. It can be mounted on fixed supports, automatic machines or robots.

The assembly of the gun on base enables a quick interchangeability reducing the non-working period. The disassembly and the assembly of the gun are carried out without removing the hoses.

The gun is fitted with an indexing aircap (1/4 turn position) and of a stop needle with indexing (adjustment to optimize the little flow rates).

There are two kind of A 35 gun with base :

A 35 HTi : high transfer rate gun (recommended for water-based materials)

A 35 HPA : high atomizing power gun (recommended for high dry extract materials).

Depending upon the installation, choose a base with lateral material connection or a base with rear material connection.

2. TECHNICAL FEATURES

FEATURES	A 35 HTi + E3 KHVLP aircap	A 35 HTi + EP 3 aircap	A 35 HPA + EN 3L aircap
Color (body)	grey	grey	blue
Maximum air supply pressure	6 bar / 87 psi		
Maximum material supply pressure	6 bar / 87 psi		
Minimum control air pressure	3 bar / 43.5 psi		
Recommended spraying air pressure	2 bar / 29 psi	2.5 bar / 36.2 psi	From 3 to 5 bar / from 43.5 to 72.5 psi
Working range	From 1.5 to 2.5 bar / from 21.7 to 36.3 psi	From 2 à 3 bar / from 29 to 43.5 psi	From 2.5 to 5.5 bar / from 36.2 to 79.8 psi
Air consumption	From 20 to 30 m3/h / from 11.8 to 17.6 c.f.m	From 21 to 29 m3/h / from 12.3 to 17 c.f.m	From 24 to 44 m3/h / from 14.1 to 26 c.f.m
Fluid flow rate	Depending upon nozzle version		
Weight (gun only)	497 g / 1.1 lb		
Use maximum fluid temperature	50°C / 122° F		
Shades and hydro or water-based varnishes			
- low viscosity	* * * *	* * *	* * *
- medium viscosity	* * * *	* * * *	* * * *
- high viscosity	* *	* * *	* * * *
Transfer rate (EN 13966-1 standard) (α)	74 % ± 2 %	72 % ± 2 %	63% ± 2 %
Wetted parts	Steel - Treated steel		
Fluid circulation	Circulation in the base		

(α) : Paint viscosity : 20 s CA n° 4 - 20°C / Distance between gun aircap and part to be painted : 20 cm

/ 8 "

Note : For HVLP compliance, the maximum inlet air pressure at the gun base must not exceed 27.5 psi (1.9 bar) to maintain 10 psi (0,68 bar) or less at the air cap. Testing for HVLP compliance was performed using the specified HVLP test air cap, the fan control fully open and a pressure gauge on the air inlet fitting at the gun base. It may also be a requirement of some regulatory agencies that users have the appropriate test air cap available on site to verify that the gun is being operated within the regulatory limitations.

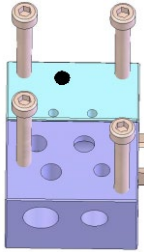
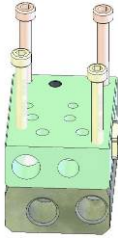
	Base (⊥) (lateral outlets)	Base (⊥) (rear outlets)
Model		
Weight (base only)	240 g / 0.45 lb	480 g / 0.90 lb
Base	Supplied with the gun	
Material (base)	Aluminium with stainless steel insert	
Weight (gun + base + fittings)	856 g / 1.9 lb	1096 g / 2.4 lb

▪ **AIR AND FLUID FITTINGS**

Supply	Threadings (base)	Fittings (base)	Hoses
Material (P1-P2)	F 1/4 NPS	Quick release fitting	Hose, model \varnothing 6 x 8
Spraying air (AP)	F 1/4 NPS	M 1/4 NPS	For the A 35 HPA gun : Air hose, minimum ID 6.5 mm / 0.3" (for a 7.5 m / 24 ft length). For the A 35 HTi gun : Air hose, minimum ID 8 mm / 5/16 (for a 7.5 m / 24 ft length).
Control air (AC)	F 1/8 NPS	Quick release fitting	Polyamide hose, model \varnothing 4 x 6

On the base, you can install :
 - 2 fluid fittings (P1 - P2) → fluid circulation
 - 1 fluid fitting and a plug

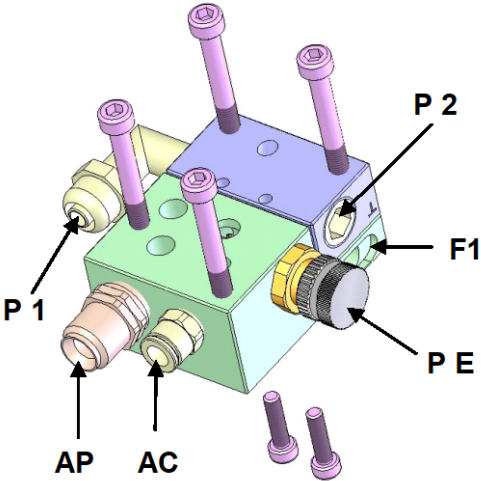
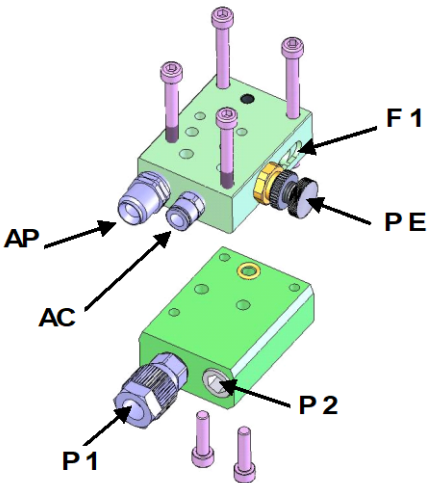

Applicate glue on the threading of the fluid fitting or on the plug before the assembly (Loctite 577 glue).

	
<p>Fixation of the gun on the base : 4 screws, model M 5 x 40</p>	<p>Fixation of the gun on the base : 2 screws, model M 5 x 60 (at the front) and 2 screws, model M 5x 40 (at the rear)</p>

Air adjuster needle (PE) → adjustment of the fan width

Fixation of the whole (gun-base) on F1 : rod model \varnothing 16, 100 mm length.

▪ DIMENSIONS : A35 GUN WITH LATERAL CONNECTION BASE

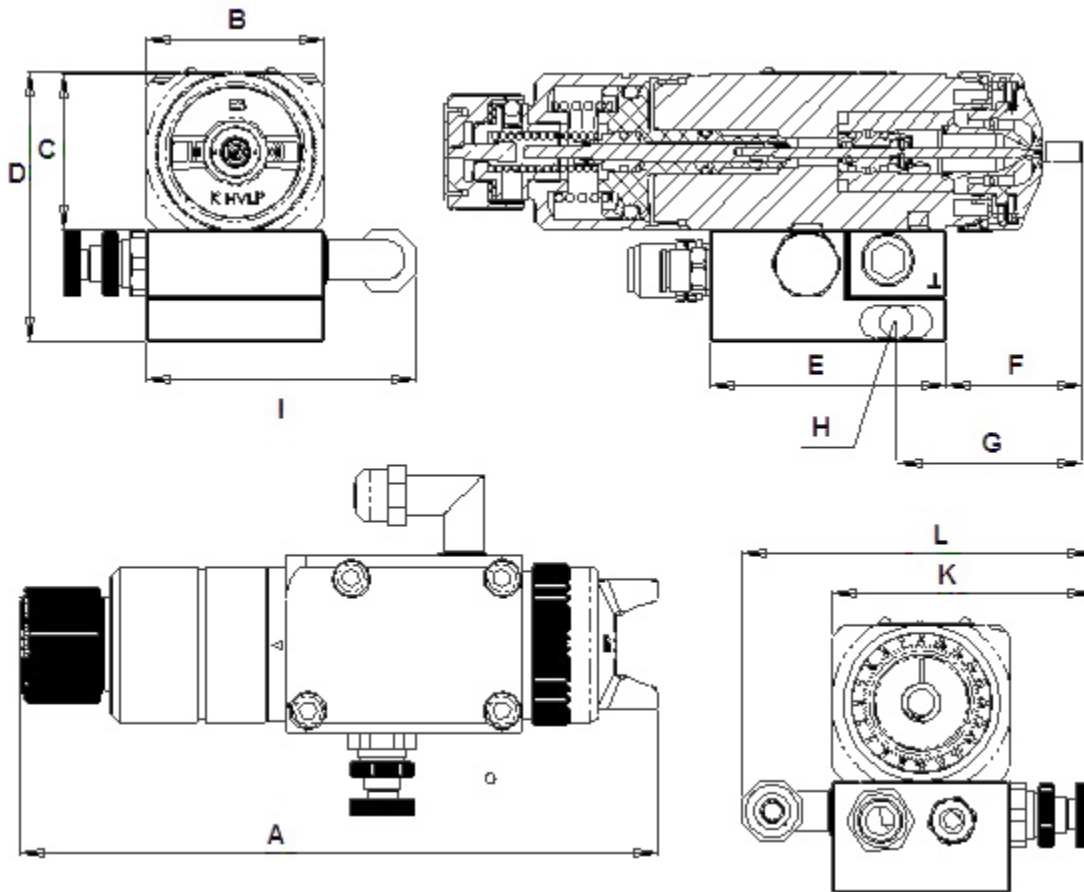

Ind.	A	B	C	D	E	F	G	H	I	K	L
mm	162	44.5	39	67.5	59	33	45	Ø 8	67	65	88
"	6.4	1.75	1.5	2.65	2.3	1.3	1.8	5/16	2.6	2.5	3.5

Base (underside view)

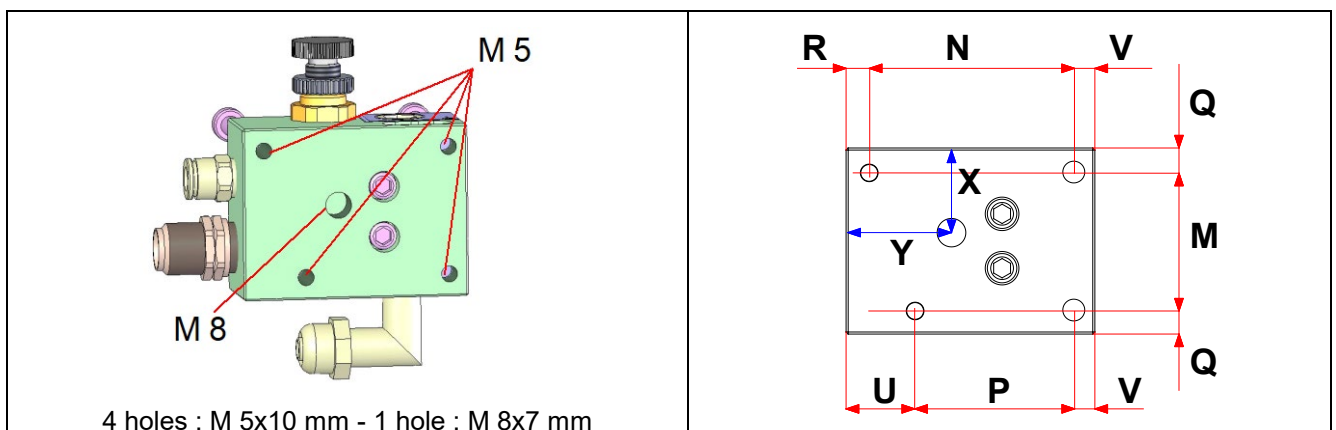

Ind.	M	N	P	Q	R	U	V	X	Y
mm	33	48.5	37.7	5.75	5,5	16,3	5	20.25	25
"	1.3	1.9	1.5	0.23	0.22	0.6	0.2	0.8	1

▪ **DIMENSIONS : A35 GUN WITH REAR CONNECTION BASE**

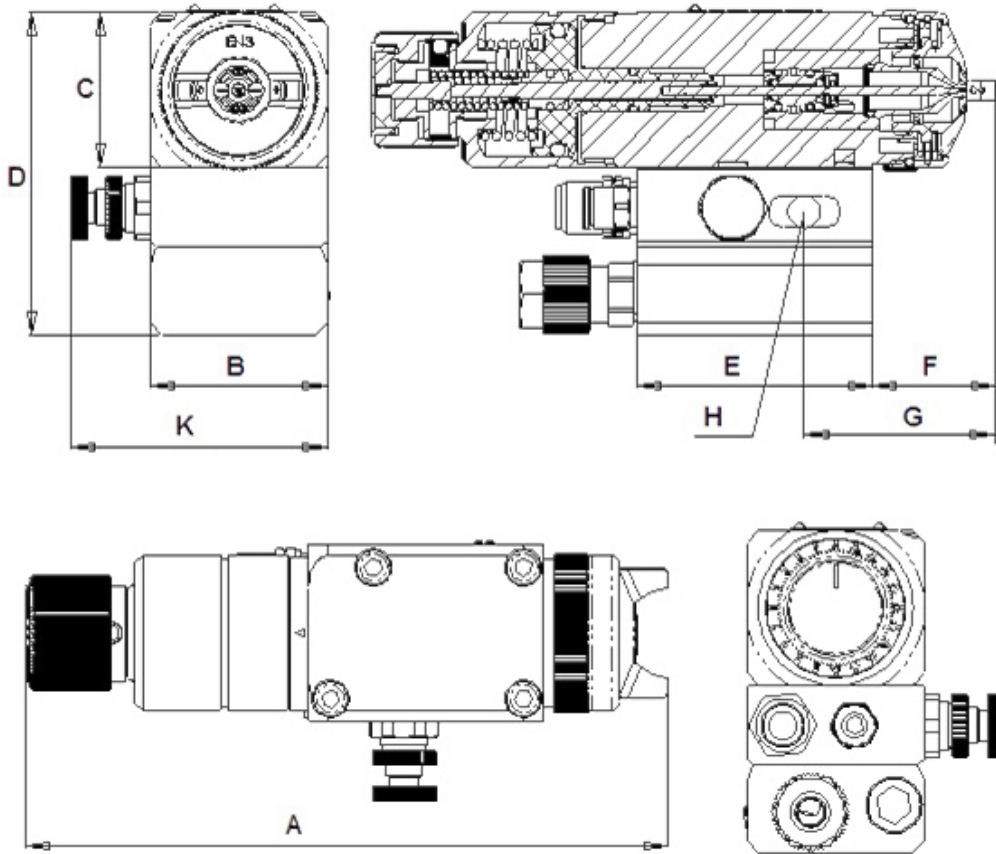

Ind.	A	B	C	D	E	F	G	H	K
mm	162	44.5	39	81	59	33	45	Ø 8	65
"	6.4	1.75	1.5	3.2	2.3	1.3	1.8	5/16	2.5

Base (underside view)

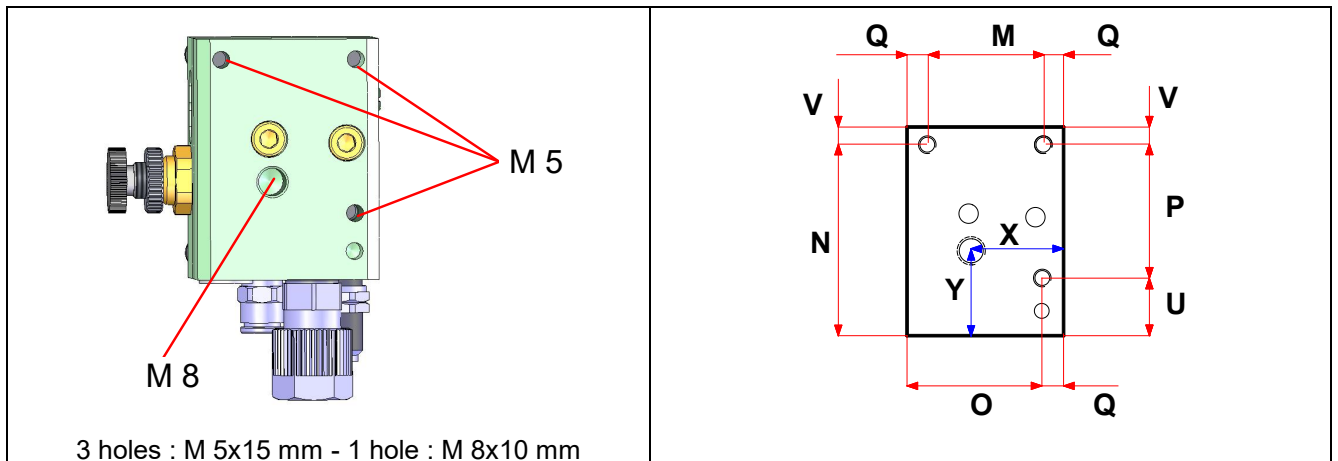

Ind	M	N	O	P	Q	U	V	X	Y
mm	33	54	38.75	37.7	5.75	16.3	5	26.25	24
"	1.3	2.1	1.5	1.5	0.3	0.6	0.2	1	0.9

▪ **OUTPUTS AND FAN WIDTHS**

Nozzle version	Paint output (g/mn - oz/mn)	Minimum / maximum fan width (cm / ")		
		A 35 HTi + E3 KHVLP aircap	A 35 HTi + EP 3 aircap	A 35 HPA + EN 3L aircap
06	150 - 5	From 10 to 25 cm / from 4 to 10"	From 10 to 24 cm / from 4 to 9.5"	From 10 to 30 cm / from 4 to 11.8"
07	200 - 6.5	From 10 to 29 cm / from 4 to 11"	From 10 to 25 cm / from 4 to 10"	From 10 to 31 cm / from 4 to 12"
09	250 - 8	From 10 to 35 cm / from 4 to 14"	From 10 to 31 cm / from 4 to 12"	From 10 to 34 cm / from 4 to 13.4"
12	300 - 10	From 10 to 38 cm / from 4 to 15"	From 10 to 32 cm / from 4 to 12.6"	From 10 to 38 cm / from 4 to 15"
15	350 - 11.7	From 10 to 41 cm / from 4 to 16"	From 10 to 34 cm / from 4 to 13.4"	From 10 to 39 cm / from 4 to 15.4"
18	400 - 13.5	From 10 to 43 cm / from 4 to 17"	From 10 to 38 cm / from 4 to 15"	From 10 to 41 cm / from 4 to 16"

Test conditions for the measure of the fan width :

Paint viscosity : 20 s CA n° 4 - 20°C, distance between the gun aircap and the part to be painted : 20 cm / 7.9"

Air pressure = 2 bar / 29 psi for the A 35 HTi gun + E3 KHVLP aircap

Air pressure = 2.5 bar / 36.3 psi for the A 35 HTi gun + EP 3 aircap

Air pressure = 3 bar / 43.5 psi for the A 35 HPA gun + EN 3L aircap

▪ **ADJUSTMENT OF THE NEEDLE INDEXING**

The adjustment enables to fine little outputs :

- Choose the nozzle most adapted to the spraying,
- Unscrew completely the needle stop,
- Screw the needle stop until getting the desired output (that operation decreases the needle stroke).
- Take down the corresponding graduation on the ring to repeat the same adjusting.

Nota : 1 stop turn corresponds to a needle stroke of 1 mm (4 maximum turns).

1 graduation corresponds to a needle stroke of 5/100 mm.

➡ **Caution : do not reduce the output if it is not useful. Leave then the opening of the needle to its maximum.**

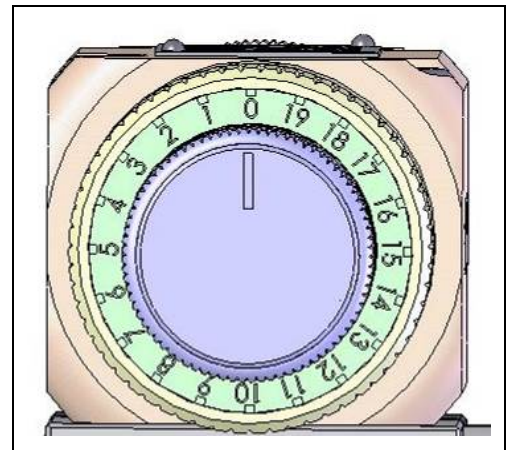



3. INSTALLATION

▪ DESCRIPTION OF THE LABEL MARKING

Label marking
(ex. : A 35 HTi gun)
Marking in accordance
with the ATEX regulation



	Description
Code SAMES KREMLIN	Manufacturer's brand
A35 HTI	Model of the gun
CE	CE : European conformity
 II 2 G	 : Use in explosive areas II : group II 2 : category 2 surface equipment intended for use in environments where explosive atmospheres due to gases, vapors, mists are likely to occur occasionally during normal operation. G : gas
Ex h IIB T6	Ex Marking of conformity to European standards h : Protection mode for non-electrical devices IIB : Reference gas for equipment qualification T6 : Temperature class - Maximum surface temperature: 85°C*.
Gb	Gb : Equipment protection level (zone 1 gas)
X	Special conditions apply for safe use. Refer to the requirements in the instruction manuals accompanying this product.
P air : 6 bar / 87 psi	Maximum air supply pressure to the gun
P prod : 6 bar / 87 psi	Maximum fluid pressure at gun inlet
	Number given by SAMES KREMLIN. The first two digits indicate the year of manufacture.

SAMES  **KREMLIN**

STAINS FRANCE

A35 HPA

CE

 II 2G Ex h IIB T6 Gb X

Pair : 6bar / 87psi

Pprod : 6bar / 87psi



INSTALLATION DIAGRAM

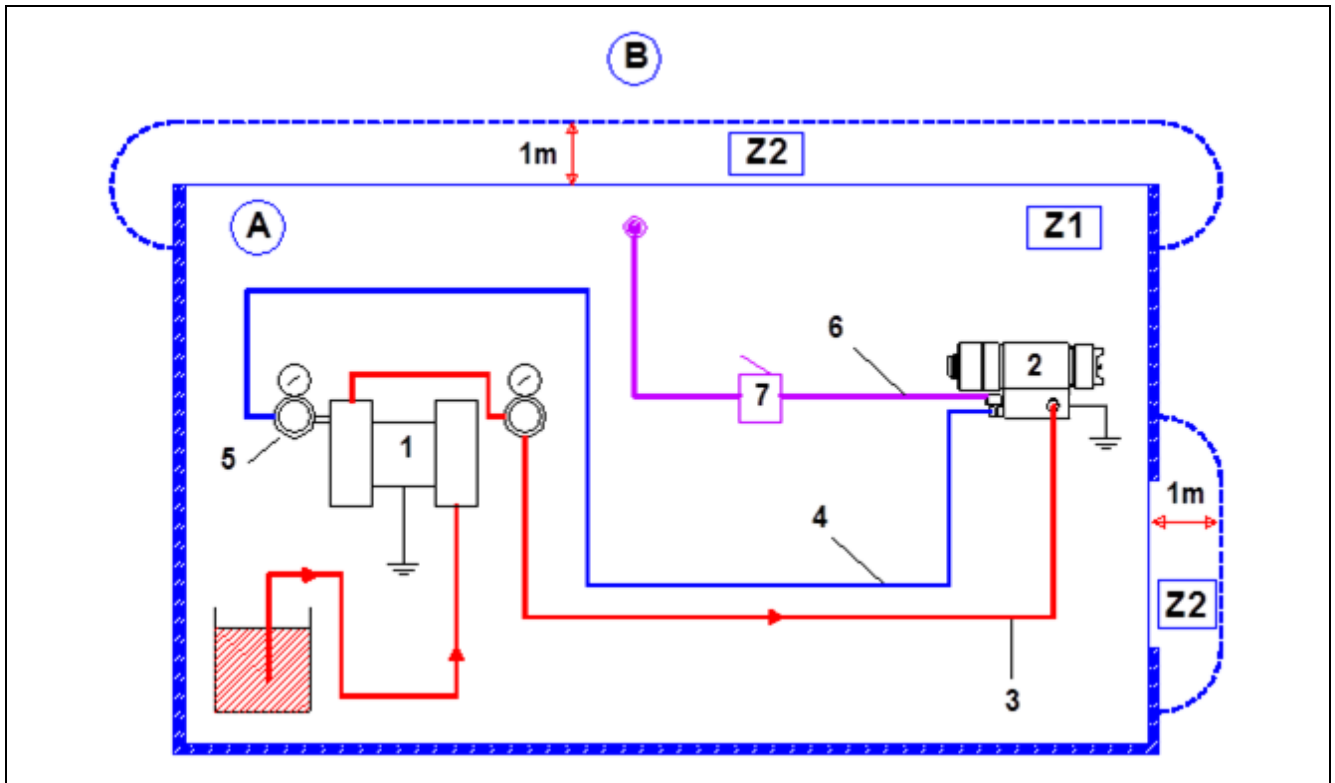

Captions :

A	Explosive area area 1 (Z1) or area 2 (Z2) : spray booth
B	Non explosive area

1	Pump
2	Pneumatic automatic gun

3	Fluid hose
4	Conductive air hose (spraying air)
5	Air regulator
6	Air hose (control air)
7	3 way-valve or electrovalve

- 1 - By means of a fluid hose (3), connect the gun fluid fitting to the pump. Tighten firmly the fittings.
- 2 - By means of a **conductive** air hose (4), connect the gun 'Spraying air' fitting (2) to an air regulator (5) that can supply at least 3 bar / 43.5 psi (→ spraying air).
- 3 - By means of an air hose (6), connect the gun 'Control air' fitting to the valve or the electrovalve (7) that will control the opening and the closing of the gun.

A minimum pressure of 3 or 4 bar / 43.5 or 8 psi is necessary to control the gun (→ control air).



Nota : The gun (and its eventual base) **must be** grounded by, **at least**, one of the three next solutions :

- by means of the fixing device on the machine,
- by means of the static conductive air hose,
- by means of the conductive or static conductive fluid hose.

The ground resistance between the gun and the floor must be $\leq 1 \text{ M}\Omega$.



The 1 m / 39.37" distance indicated in these diagrams is given for information purposes only and hold harmless to SAMES KREMLIN. The user is responsible for the extraction and conditioning of the painting area where the equipment is used, for working conditions conditions (refer to EN 60079-10 standard). The 1 m / 39.37" distance may be modified if trials carried out by the user deem this necessary.