

sames  kremlin



# Nanogun+ Airmix® – GNM 6080

LR- HR- MR Versions

Instruction manual

**DRT7115**

E - 2022/11

**Sames**

13, Chemin de Malacher - 38240 MEYLAN - FRANCE  
Tel. 33 (0)4 76 41 60 60

All communication or reproduction of this document, in any form whatsoever and all use or communication of its contents are forbidden without express written authorisation from **Sames**.

The descriptions and characteristics mentioned in this document are subject to change without prior notice

© **Sames 2016 - translation of the original version**

**Sames** operating manuals are written in French and translated into English, German, Spanish, Italian and Portuguese. The French version is deemed the official text and **Sames** will not be liable for the translations into other languages.

## Services



### Certification and referencing

**Sames** is certified as a training center by the DIRRECTE of the Auvergne Rhône Alpes region under the number 84 38 06768 38.

Our company provides, throughout the year, training courses allowing you to acquire the essential know-how for the implementation and maintenance of your equipment in order to guarantee its performance in the long term.

A catalog is available on request.

[www.sames.com/france/fr/services-training.html](http://www.sames.com/france/fr/services-training.html)



### Line audits

As part of a technical assistance program for our customers using **Sames** equipment, the line audits are intended to help you optimize and control your production tool.

Our network of experts is continuously trained and qualified to provide our customers with technical expertise on the liquid or powder installations in which our equipment is integrated. The global environment of the production lines is taken into account during this technical audit.

A brochure is available for download:

[www.sames.com/france/fr/services-service-contract.html](http://www.sames.com/france/fr/services-service-contract.html)



### Maintenance program

An annual maintenance program (including or not the consumables to be replaced during each intervention) can be considered with the partnership of **Sames**. It is associated with a preventive maintenance plan established during a first audit visit which details the control points necessary to guarantee the performance of the installed equipment.

[www.sames.com/france/fr/services-service-contract.html](http://www.sames.com/france/fr/services-service-contract.html)



### Hotline

[www.sames.com/france/fr/services-service-contract.html](http://www.sames.com/france/fr/services-service-contract.html)

---

# Nanogun+ Airmix®- GNM 6080

1. Health and Safety Instructions - - - - -	7
1.1. Marking .....	7
1.1.1. By the barrel.....	7
1.1.2. On the lower part of the gun handle.....	7
1.2. GNM 6080 control module .....	8
1.3. Precautions for use .....	9
1.4. Meaning of pictograms .....	10
1.5. Warnings .....	11
1.6. Regulations .....	11
1.7. Installation rules .....	12
1.8. Operating rules .....	13
1.9. Maintenance rules .....	15
1.9.1. Products used.....	16
1.10. Guarantee .....	17
2. Description of spray gun and GNM 6080 control module - - - - -	18
2.1. Functions available on spray gun .....	18
2.2. GNM 6080 Control module .....	19
3. Technical characteristics - - - - -	22
3.1. General spray gun characteristics .....	22
3.2. Flows .....	23
3.2.1. Versions without whip (LR).....	23
3.2.2. Version with whip (HR-MR).....	24
3.3. GNM 6080 Characteristics .....	25
3.4. Operation .....	26
3.5. For use .....	26
3.5.1. Viscosity.....	26
3.5.2. Resistivity .....	26
3.5.3. Settings of the spraying parameters .....	26
4. Electric diagrams - - - - -	28
4.1. Connection cable GNM 6080 / Nanogun+ Airmix® .....	28
4.2. GNM 6080 trigger cable .....	28
5. Start-up - - - - -	29
5.1. Tools .....	29
5.2. Using the multipurpose spanner .....	31
5.3. Installation .....	32
5.3.1. With piston pump for all versions.....	32
6. Maintenance - - - - -	33
6.1. Summary table of maintenance operations .....	33
6.2. Preventive maintenance plan - PMP 7115 .....	34
6.3. Cleaning .....	34
6.3.1. Procedure A1 : Cleaning the product circuit.....	34
6.3.2. Procedure A2 : Cleaning the spray gun .....	35
6.3.3. Procedure A3: Hollow cone nozzle cleaning .....	36
6.3.4. Procedure A4: Waste disposal.....	37
6.3.5. Procedure A5: Demolition and Recycling .....	38



6.4. Replacement .....	40
6.4.1. Procedure B1: Replacement of the paint hoses.....	40
6.4.2. Procedure B2: Replacement of the spray head assembly.....	42
6.4.3. Procedure B3: Replacement of the electrode located in the air cap.....	43
6.4.4. Procedure B3: Replacement of the paint needle.....	45
6.4.5. Procedure C1: Replacing the seals cartridge.....	48
6.4.6. Procedure C2: Replacement of the air valve.....	50
6.4.7. Procedure C3: Replacement of the high voltage cascade.....	52
6.4.8. Procedure D1: Replacement of the electropneumatic coupling.....	53
6.4.9. Procédure D2: Remove paint hose. Loosen the paint hose nut with a 15mm open-ended spanner.....	54
6.4.10. Procedure D3: Replacement of the switch.....	56
6.4.11. Procedure D4: Replacement of the trigger.....	56
6.4.12. Procedure D5: Replacement of the fixing hook.....	57
7. Troubleshooting Guide -----	58
8. Spare Parts -----	60
8.1. Nanogun+ Airmix® guns for both high resistivity (HR) solvent-based paints ...	61
8.1.1. 120 bar version.....	62
8.1.2. 200 bar version.....	64
8.1.3. The nozzles as an option.....	66
8.1.4. Fitted air cap ring.....	67
8.1.5. Equipped Air cap.....	67
8.2. Nanogun+ Airmix® spray guns.....	68
8.3. Equipped seat casing (Flat spray only).....	71
8.4. Equipped adapter (Flat spray only).....	71
8.5. Barrel assembly.....	72
8.6. Air valve and Nut air valve.....	73
8.7. Needle assembly.....	74
8.8. Electropneumatic coupling sets.....	74
8.9. Paint hoses.....	75
8.9.1. Pour pistolets Nanogun+ Airmix® HR.....	75
8.9.2. For Nanogun+ Airmix® LR guns.....	76
8.9.3. For Nanogun+ Airmix® MR guns.....	77
8.10. Nanogun+ Airspray seal set.....	78
8.11. Hollow cone kit.....	79
8.11.1. Equipped hollow cone seat casing.....	80
8.11.2. Procedure for changing from a flat spray to a round spray.....	81
8.12. GNM 6080 Control module.....	82
8.13. Options for Nanogun+ Airmix® guns.....	82
8.14. Various.....	83
8.14.1. Protective hose covering.....	83
8.14.2. Protective case for spray gun.....	83
8.14.3. Warning notice.....	83
8.14.4. Safety valve.....	83
9. The different versions -----	84
9.1. Equipments.....	84
9.2. Configuration.....	85
10. Revision index History -----	86

---

11. Appendices -----	87
11.1. Maintenance preventive plan .....	87
11.2. EU and UK Declarations of conformity .....	88

## 1. Health and Safety Instructions

### 1.1. Marking

The **Nanogun+ Airmix®** gun markings will allow differentiating between the 120-bar and the 200-bar model configuration.

#### 1.1.1. By the barrel

All **Nanogun+ Airmix®** range products carry the same markings on the barrel.

These equipment is designed in accordance with ATEX Directive 2014/34/EU and SI 2016 No. 1107, is Category 2, and is intended for use in Zone 1.

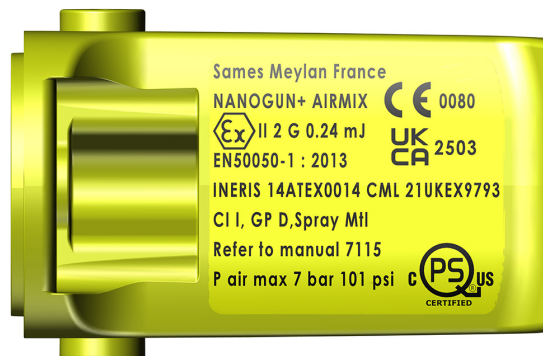

#### 1.1.2. On the lower part of the gun handle

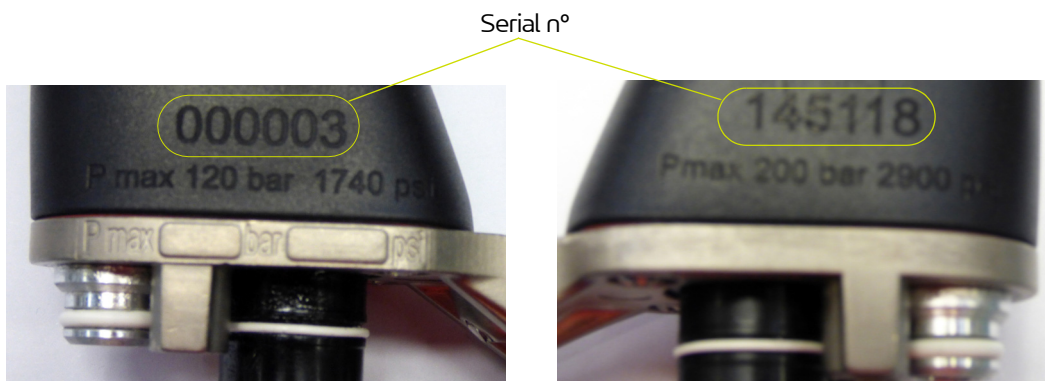

This marking groups together all spray gun configurations operating at the same product pressure under the same number.

Pressure generated	Nanogun+ Airmix® versions
120 bar	JP-LR; JP-MR; JP-HR
200 bar	JP-LR; JP-MR; JP-HR

### 1.2. GNM 6080 control module

The **GNM 6080** control module should not be installed in an ATEX zone (potentially explosive atmosphere). It is defined as “associated material” according to ATEX Directive 2014/34/EU and SI 2016 No. 1107.

#### Markings

**EU / UK versions**

Sames Meylan France

GNM6080  
910017193

CE 0080

UK CA 2503

IP20

88 - 264V~ 50/60Hz 25VA  
U output : 40V rms  
I output : 200mA rms

II (2) G  
INERIS14ATEX0014  
[0,24mJ]  
CML21UKEX9793  
EN 50050-1:2013

Admissible combinations of devices,  
see information for use

2022 26123 \*

Version Software:  
S/N :

DES08772

**US / C versions**

Sames Meylan France

GNM6080  
910017192

IP20

88 - 264V~ 50/60Hz 25VA  
U output : 40V rms  
I output : 200mA rms

PSI US  
CERTIFIED

2022 26123 \*

Version Software:  
S/N :

DES08773

**Example: \* 2022: Year of manufacturing**  
**26: Week number**  
**123: Nth control module made in the week 26.**



Equipment Nanogun+ Airmix® is in accordance with the functional safety standard (Standard EN13849, level SIL 1), the preservation of this level of safety imposes a periodic control of the equipment, in minima every 5 years or 15000 hours of functioning (to the first one 2 reached). This control concerns each of the electric and electronic components as well as on it or the very specific programs, you have to get in contact with your subsidiary, distributor or usual representative of SAMES KREMLIN who will indicate you the steps to be carry out.

### 1.3. Precautions for use

This document contains information that all operators should be aware of and understand before using the **Nanogun+ Airmix<sup>®</sup>**. This information highlights situations that could result in serious damage and indicates the precautions that should be taken to avoid them.



**Before any use of the Nanogun+ Airmix<sup>®</sup> spray gun, check that all operators:**

- have previously been trained by the company **Sames**, or by their distributors registered by them for this purpose.
- have read and understood the user manual and all rules for installation and operation, as listed below.

**It is the responsibility of the operator's workshop manager to ensure these two points and it is also his responsibility to make sure that all operators have read and understood the user manuals for any peripheral electrical equipment present in the spraying area.**

1.4. Meaning of pictograms

				
Warning electricity	Warning Automatic start	Warning Hot surface	Warning Explosive material	General warning sign
				
Danger High pressure	Warning Crushing of hands	Warning for explosive atmospheres	Warning Flammable material	No access for people with active implanted cardiac devices
				
Wear ear protection	Wear a face shield	Wear respiratory protection	Wear safety footwear	Wear protective clothing
				
Wear head protection	Opaque eye protection must be worn	Wear protective gloves	General mandatory action sign	Connect an earth terminal to the ground
				
Refer to Instruction manual				

## 1.5. Warnings



It is imperative that anyone wearing a pacemaker does not use the equipment and does not enter the projection area.  
High voltage can cause the pacemaker to malfunction.



This equipment may be dangerous if not used, disassembled and reassembled in accordance with the rules specified in this manual and any applicable European Standard or national safety regulations.

The warning notice summarizing the safety rules (procedures and precautions) laid out in this instruction manual must be clearly displayed in the area of the spraying workstation.



The correct operation of the equipment is guaranteed only with the use of original spare parts distributed by Sames.



In order to ensure optimum assembly, spare parts should be stored at a temperature close to their operating temperature. If not, a sufficient waiting time must be observed before installation, so that all parts are assembled at the same temperature.

## 1.6. Regulations

The **Nanogun+ Airmix<sup>®</sup>** spray gun must always be used according to the requirements stipulated in the standards and regulations in force concerning painting and clear coat methods (see Standards and Directives EN 50.053 part 1 ISO 12100, EN 1953 and 99/92/CE).

In **Canada**, the installation has to be in compliance with the code " electrical C22.1 Canadian code, part I, standard safety for electrical installations ".

In the **USA**, the installation has to be in compliance with the code " NFPA 70: National Electrical Code ".

CAUTION: Model **Nanogun+ Airmix<sup>®</sup>** spray applicator is suitable for use in **CLASS I, DIVISION 1, GROUP D HAZARDOUS LOCATIONS**" when connected to model GNM 6080 power supply unit.

The Pollution Degree Rating of the **Nanogun+ Airmix<sup>®</sup>** is "Pollution Degree 2" following IEC-664-1 standard  
**Pollution Degree 2:** Normally only non-conductive pollution occurs. Temporary conductivity caused by condensation is to be expected.



**Before any use of the Nanogun+ Airmix<sup>®</sup> spray gun, check that all operators**

- have previously been trained by the company or by their distributors registered by them for this purpose.
- have read and understood the user manual and all rules for installation and operation, as listed below.

**It is the responsibility of the operator's workshop manager to ensure these two points and it is also his responsibility to make sure that all operators have read and understood the user manuals for any peripheral electrical equipment present in the spraying area.**

### 1.7. Installation rules

- The manual projection electrostatic material must be used only in projection area according to the standard EN 16985 or in equivalent conditions of ventilation.
- The control module must **not be installed where there is a potential explosion risk**.
- It must be impossible to start up the control module before the spray booth air extraction system is in operation.
- Connect the control module correctly to the earth terminal of the installation to avoid electromagnetic interference. The resistance between the module's earth and the installation's earth should be as low as possible, in the order of a few ohms.
- The paint (or solvent) pump and tank must be connected to a ground terminal on the device.
- All metal parts of the apparatus (paint pumps, containers, stools, turntables, etc.) less than three metres from the spray gun must be grounded.
- The spraying area must be kept clean and clear of any unnecessary items.
- The floor on which the operator works must be dissipator (bare concrete or metal duckboard). Never use an insulating floor covering. In area potentially explosive, the assemblies of grounds have to be dissipators according to the standard EN 61340-4-1.
- Naked flames, glowing objects or a devices likely to produce sparks (other than the atomizer) must not be used inside the booth.  
The storage of inflammable products, or vessels that have contained them, close to the booth or in front of the doors is prohibited.
- Pots and tubs containing paint or solvent must always be closed after use.
- The paint supply pump used must have a maximum ratio of 1:1 and the pump air supply must be fitted with a safety valve limiting the pressure to 6.5 bar maximum.
- **In the explosive area**, it is forbidden to use any non-certified electrical or non-electrical equipment such as electronic extension leads, multiple socket adapters, switches, etc.



## 1.8. Operating rules

- The ventilation system must be checked on a daily basis to ensure it is working properly.
- Performance checks must be carried out on the extraction control system once a week.
- Before starting to spray, check that the nozzle/tip and air cap are fitted to the gun and that the air cap ring is fully tightened.
- All metal parts of the booth and parts to be painted must be correctly grounded. Ground resistance must be less than or equal to 1 MΩ. (measurement voltage 500 V). This resistance value must be regularly checked.
- The operator must wear dissipator shoes according Standard EN 61340-4-3 and hold the **Nanogun+ Airmix<sup>®</sup>** spray gun bare-handed or with gloves that are either dissipators or specially adapted to allow direct contact between the handle and the operator's hand. Shoes intended to be worn by the operator have to be in accordance with the standard ISO 20344. The measured insulating resistance does not have to exceed 100 MΩ.
- Protective clothings intended to be worn, including gloves, have to be in accordance with the standard EN 1149-5. The measured insulating resistance does not have to exceed 100 MΩ.
- The operator must also wear ear defenders when using **Nanogun+ Airmix<sup>®</sup>** spray guns ([see § 1.3 page 9](#)).
- Ensure that anyone who enters the spraying area is wearing dissipator shoes or is otherwise grounded.
- Never throw or drop deliberately the electrostatic spray gun. Dropping the gun could damage the high voltage generator. After a drop, it is advised to verify the functioning of the pistol out off zone before its re-use.
- Never point the spray gun towards a person.
- Check the spray gun at least 1 time a week.
- Never use the apparatus in the following situations:
  - 1 If you notice an air leak from the spray gun when the trigger is released.
  - 2 If the spray gun electrical connector catch is not held securely in place with two safety screws.
  - 3 If the spray gun barrel, handle show signs of an impact that may have deteriorated the air-tightness of internal components.
- The manual electrostatic projection equipment must be exploited only if it is in a perfect state. A damaged equipment must be immediately removed from the installation and must be repaired. The worn out components must be immediately replaced.
- Follow the precautions specified for the paints and solvents used (e.g. wear a mask etc.).
  
- Close and dump the air and paint supply before leaving the device shut down for an extended period.
- Check the paint hose is in good condition before starting to operate the device.
- The electropneumatic coupling, held in place by two safety screws **MUST NEVER BE DISCONNECTED IN A POTENTIALLY EXPLOSIVE ATMOSPHERE.**
- If any of the following elements are damaged, all operations with the device must be stopped: barrel, handle, electropneumatic coupling, air cap or air cap ring.



Sames would like to remind users that the instructions below **MUST** be strictly complied with.

<b>It is forbidden</b> to install the control module in a potentially explosive atmosphere.
<b>It is forbidden</b> to subject the paint or air hose or spray gun power cable to excessive and repeated tension strain.
<b>It is forbidden</b> to disconnect the electrical connector in a potentially explosive atmosphere.
<b>It is forbidden</b> to leave air or paint hoses trailing on the floor or in areas where they are liable to be crushed or broken by industrial vehicles.
<b>It is forbidden</b> to use the <b>Nanogun+ Airmix®</b> to spray a liquid other than a paint or clear coat.
<b>It is forbidden</b> to drop the spray gun or subjecting it to impacts.
<b>It is forbidden</b> to leave the spray gun on the ground.
<b>It is forbidden</b> to use the spray gun to handle or move the parts to be painted.
<b>It is forbidden</b> to leave the spray gun to soak in solvent or spraying it with solvent.
<b>It is forbidden</b> to spray solvent before switching off the control module.

<b>It is essential</b> to connect the control module ground terminal to the paint apparatus ground terminal.
<b>It is essential</b> to tighten the two safety screws on the electrical connector.

## 1.9. Maintenance rules



During the 12-month warranty period, it is strictly forbidden to dismantle the Nanogun+ Airmix<sup>®</sup> gun except to carry out maintenance in accordance with the maintenance instructions ([see § 6 page 33](#)).

- Service regularly and repair the electrostatic spraying equipment in accordance with the instructions in this user manual.
- Metal containers only should be used to hold cleaning liquids and they must have a reliable ground connection.
- Before any maintenance or servicing operation:
  - 1 Disconnect the control module from the power supply.
  - 2 Check that the air and paint circuits are not pressurized.
  - 3 Dump the paint Circuit
  - 4 All the energy sources must be consigned.
- Cleaning operations must be carried out either in authorised areas equipped with a mechanical ventilation system, or using cleaning liquids with a flash point at least 15 °C higher than the ambient temperature.
- Use non flammable cleaning products preferably.
- Do not reconnect the electrical power supply until the air cap and nozzle/tip have been correctly reassembled on the spray gun.
- Never soak or immerse the spray gun in solvent. If required, the spray gun may be cleaned by wiping with a cloth soaked in solvent and then immediately dried to prevent the solvent entering the spray gun.



**Never spray solvent whilst the control module is live and/or the switch located on the back of the gun is in position «|».**



**The cut of the compressed air supply does not prohibit the release of the high voltage when the trigger is activate.**

- Operators must be trained by **Sames**, or by their distributors registered by them for this purpose, to perform **Nanogun+ Airmix<sup>®</sup>** spray gun maintenance operations.



**It is forbidden to use oil-based solvent and products containing such solvents if aluminium or zinc are present. Users who do not follow these instructions are exposed to explosion risks.**

### 1.9.1. Products used

Given the wide range of products used, and that fact that it is impossible to produce an inventory of these products, **Sames**, cannot be held liable for:

- incompatibility of product material used when in contact with materials listed below:
  - Stainless steel
  - Fluoroethylenepropylene (FEP)
  - Polyamide-imide (PAI)
  - Polyoxymethylene (POM)
  - Tungsten carbide and Tungsten
  - PTFE elastomer
  - Polypropylene
  - IXEF
  - Glass fibre
  - Ceramics
  - Aluminium
  - Titanium
  - PEEK
  - PEHD and PEBD
  - Chemically inert rubber
- Risks related to the use of these products for personnel and the environment include.
- Wear, incorrect adjustments or malfunction of equipment or machines, together with the non-quality of the application caused by the use of these products.

### 1.10. Guarantee

Under the guarantee, which applies only to the buyer, **Sames** agrees to repair operating faults resulting from a design fault, materials or manufacture, under the conditions set out below.

The guarantee claim must define, in writing, the exact nature of the fault concerned.

The **Sames** guarantee only covers equipment that has been serviced and cleaned according to standard procedures and our own instructions, that has been fitted with parts approved by **Sames** or that has not been modified by the customer.

More precisely, the guarantee does not cover damage resulting from:

- the customer's negligence or inattentiveness,
- incorrect use,
- failure to follow the procedure
- use of a control system not designed by **Sames** or a **Sames** control system modified by a third party without written permission from an authorized **Sames** technical agent,
- flooding, earthquake, fire or similar events,
- inadequately filtered paint and solvent,
- use of seals not complying with **Sames** recommendations,
- pollution of air circuits by fluids or substances other than air.

The **Nanogun+ Airmix<sup>®</sup>** guns are covered by a one-year guarantee for use in two 8-hour shifts under normal operating conditions (5000 hours).

The guarantee does not apply to wearing parts such as nozzles, seals, etc...

The guarantee will start from the date of the first use or the provisional acceptance report.

Under no circumstances, either in the context of this guarantee or in other contexts, will Sames be held responsible for physical injury or intangible damage, damage to brand image and loss of production resulting directly from its products.

## 2. Description of spray gun and GNM 6080 control module

**Nanogun+ Airmix<sup>®</sup>** spray guns are designed to spray paint or clear coat whose resistivity is greater than 0.5MΩ.cm. only.

The configurations LR can moreover spray hydrodiluable paints or clear coats when they are equipped with the suitable produced means of supply. The use of any other type of paint is excluded.

**Nanogun+ Airmix<sup>®</sup> spray guns are to be connected to the GNM 6080 control module.**

The models in the **Nanogun+ Airmix<sup>®</sup>** range can be differentiated by their air cap, air cap ring, the base support and the paint hose.

	Characteristics
<b>Nanogun+ Airmix<sup>®</sup> 120 7.5</b>	Flat spray - 120 bar hose 7.5 m
<b>Nanogun+ Airmix<sup>®</sup> 120 15</b>	Flat spray - 120 bar hose 15 m
<b>Nanogun+ Airmix<sup>®</sup> 120 30</b>	Flat spray - 120 bar hose 30 m
<b>Nanogun+ Airmix<sup>®</sup> 200 7.5</b>	Flat spray - 200 bar hose 7.5 m
<b>Nanogun+ Airmix<sup>®</sup> 200 15</b>	Flat spray - 200 bar hose 15 m
<b>Nanogun+ Airmix<sup>®</sup> 200 30</b>	Flat spray - 200 bar hose 30 m

### 2.1. Functions available on spray gun

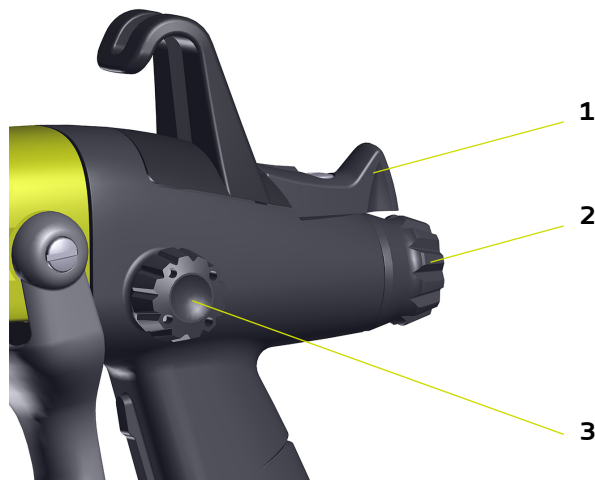

- The switch (Rep. 1) allows turning on or off the high voltage supply. When this switch is placed in position " I ", activating the trigger turns on the high voltage. When this switch is placed in position " 0 ", activating the trigger does not turn on the high voltage.
- **The detented knob in back of the gun (Rep. 2) must always be held in place (clockwise); it does not influence the paint flow rate.**
- The side detented knob (Rep. 3) serves to adjust the spray dimension. Its action will become even weaker as product pressure rises.

## 2.2. GNM 6080 Control module

The GNM 6080 control module allows the display of the parameters of use as well as their adjustments.

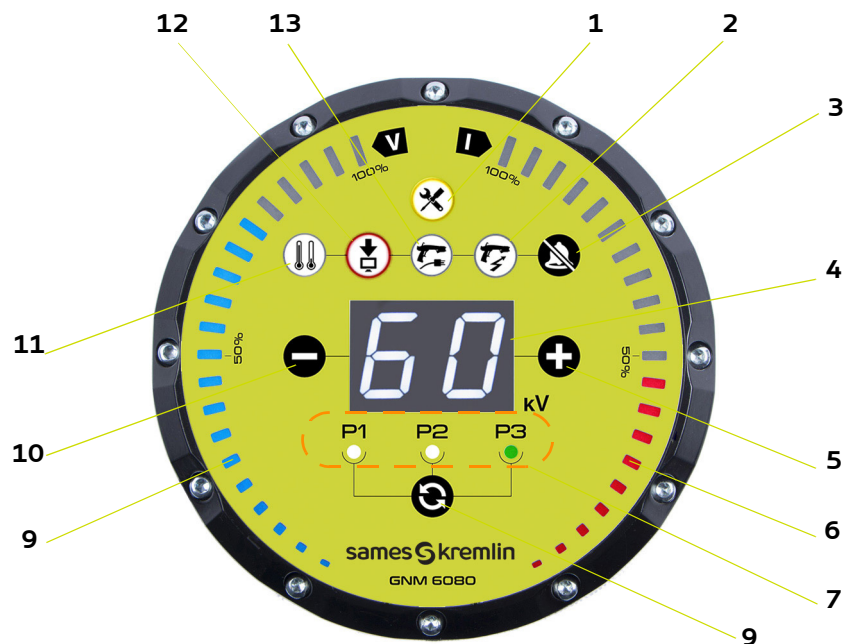

Front face of the GNM 6080 control module

1	Maintenance indicator light
2	Indicator light of high voltage fault
3	Reset of faults
4	Display of setpoint of high voltage
5	Increase of the setpoint voltage
6	Bargraph of the current consumption
7	Indicator lights of active preset memory
8	Selection of the active memory
9	Bargraph of the voltage
10	Decrease of the setpoint voltage
11	Indicator light of temperature fault
12	Indicator light of control module fault
13	Indicator light of low voltage cable



**Temperature fault :** The temperature fault forces the indicator lights (Item 11 and 12). As soon as the temperature decrease under the minimum, the temperature indicator light (Item 11) goes out and the operator can delete the fault by pressing on the button «Reset of faults» (Item 3).



**Control module fault:** this fault collects all the internal faults of the control module. If this fault can not be resetted, the problem requires the intervention of the repair department, contact **Sames**.

**Low voltage connection fault:**



- The control module does not detect or any more the presence of the gun.
- Switch off the main power supply, check the connection between the control module and the gun.
- This fault may also be related to electromagnetic interference generated by other equipment in the installation.
- Check that the module is earthed and that the other equipment complies with electromagnetic compatibility rules.

**Nota:** One or more alarm lights come on at random and sometimes it is impossible to acknowledge them, and/or the red and blue LED strips do anything when the trigger is pulled and/or nothing happens when the trigger is pulled.

**Remedies:**

Turn off the GNM and turn it back on 2 or 3 seconds later, this can be repeated 2, 3 or 4 times if it doesn't work. If it still doesn't work: Check the electronic disturbance in the vicinity of the module and the ground of the building to which the module is connected.



**High voltage faults:** faults specific to the operation of the gun related to the high voltage:

- Start up of the control module with the engaged trigger.
- Peak of an important over-current during the high voltage.
- Bad functioning of the high voltage unit.



**Maintenance indicator light:** This indicator light ignites (orange) from 800000 operations of the trigger or at the 1000 hours of functioning of the gun ([see § 6 page 33](#)).

The ignition of this light indicates that the maintenance of the gun must be carried out. No specific maintenance on the GNM 6080.

If one or more lights or barographs come on at random, after switching off the power supply to the module,

it is necessary to check that the module is earthed and that other equipment complies with electromagnetic compatibility regulations.



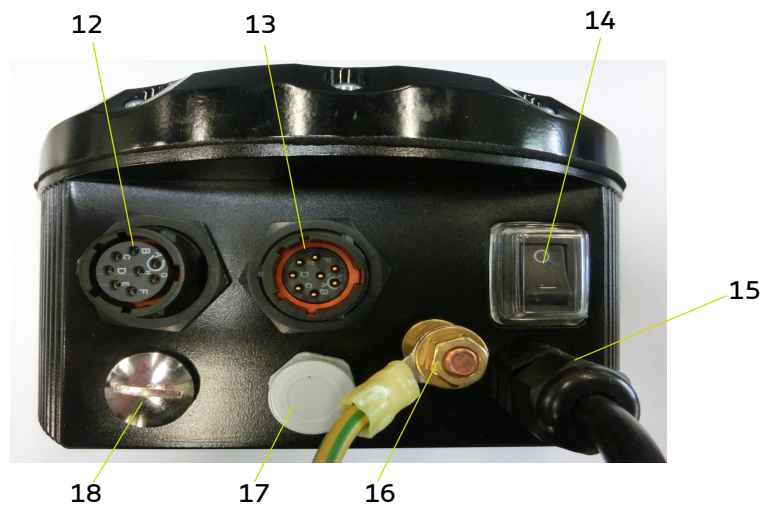

Side face of the GNM 6080 control module

<b>12</b>	Plug for gun cable
<b>13</b>	Plug for external cabling
<b>14</b>	Switch ON / OFF
<b>15</b>	Main power supply
<b>16</b>	Ground connection
<b>17</b>	Diaphragm of pressure balancing
<b>18</b>	Diagnosis plug (type mini USB)

### 3. Technical characteristics

#### 3.1. General spray gun characteristics

	120	200
Type of spray	Flat	
Original nozzle assembled	09	
Maximum incoming paint pressure	120 bar	200 bar
Incoming compressed air pressure	6 bar $\pm$ 1 bar	
Min/max ambient temperature	0°C - 40°C	
Maximum water flow rate	See table below	
Spray width at 25 cm	See table below	
Air flow rate, in Nm <sup>3</sup> /h	10.3 - 25.2	
Acoustic pressure	90 dB(A)	
AFNOR Cup No. 4 suggested paint viscosity	20 s to 120 s	
Space requirements	305 x 220 x 52	
Mass (without either the hose or the cable)	595 g	
Output voltage	60 kV maximum [+0 kV; -1.5 kV] (adjustable on GNM 6080)	
Output current	80 $\mu$ A maximum	
Output current in a short-circuit	< 20 $\mu$ A	
Input voltage of the high-voltage cascade	45 V AC maximum	
Input current of the high-voltage cascade	300 mA maximum	
Air coupling	1/4 NPS - F	
Paint coupling	1/2 JIC - F	
Paint resistivity $\rho$	10 M $\Omega$ .cm < $\rho$ < 500 M $\Omega$ .cm Version QD (high resistivity) 0.5 M $\Omega$ .cm < $\rho$ < 500 M $\Omega$ .cm (low resistivity) 2 M $\Omega$ .cm < $\rho$ < 500 M $\Omega$ .cm (middle resistivity)	
Electrical functions available on the gun	High-voltage On / Off switch	
Electrical / pneumatic connector	The electro-pneumatic connector, secured by means of two screws. <b>MUST NEVER BE DISCONNECTED IN AN EXPLOSIVE ATMOSPHERE</b>	
Maximum operating altitude	2,000 m	
Maximum relative humidity of 80% for temperatures of up to 31°C, then linear decrease until 50% relative humidity at 40°C	Maximum of 80% without condensation	
Surface temperature	T6	
Protection index	IP 20	
<b>Transport / Storage</b>		
Time spent in storage	Max. 2 years	
Min/max storage temperature	-10°C + 45°C	
Humidity	95% without condensation	
Min. pressure	750 mbar	
Exposure to UV rays	Stored out of direct light	
Exposure to ionising radiation	Not accepted	
<b>Air comprimé (selon la norme NF ISO 8573-1)</b>		
Maximum dew point at 6 bar (87 psi)	Classe 4 soit + 3°C (37° F)	
Maximum particle size of solid contaminants	Classe 3 soit 5 $\mu$ m	
Maximum oil concentration	Classe 1 soit 0,01mg / m <sub>0</sub> <sup>3</sup> *	
Maximum concentration of solid contaminants	5 mg / m <sub>0</sub> <sup>3</sup> *	

(\*): Values are given for a temperature of 20 °C (68 °F) at 1013 mbar atmospheric pressure.

**Measurement conditions:**

The apparatus was operated to maximum capacity and the measurements taken in the manual paint test booth (sealed booth with glass panels) located in the **Sames** site in Meylan, France.

**Measurement method:**

The weighted equivalent sound pressure level (93.8 et 98.6 dBA) is an LEQ value measured during observation periods over at least 30 seconds.

**3.2. Flows**

**3.2.1. Versions without whip (LR)**

**Flat spray:**

Gauge	Flow rate (in cc/min)			Width, in cm
	at 70 bar	at 120 bar	at 200 bar	
03-05	150	200	260	12
03-07	150	200	260	17
04-05	220	290	380	12
04-07	220	290	380	17
04-09	220	290	380	21
04-11	220	290	380	25
04-13	220	290	380	29
06-09	330	430	570	21
06-11	330	430	570	25
06-13	330	430	570	29
06-15	330	430	570	33
09-09	450	590	770	21
09-11	450	590	770	25
09-13	450	590	770	29
09-15	450	590	770	33
12-11	600	790	1030	25
12-13	600	790	1030	29
12-15	600	790	1030	33
14-09	720	940	1230	21
14-11	720	940	1230	25
14-13	720	940	1230	29
14-15	720	940	1230	33
14-17	720	940	1230	37

**Nota:** The flow rate measurements were conducted with water. The width of the impact is measured at a distance of 25 cm (10 inches).

**Hollow cone round spray:**

Gauge	Flow rate (in cc/min)			Impact diameter at 250 mm	Impact diameter at 250 mm
Dynamic air pressure				Nanogun+ 120 bar Spraying air 4 bars	Nanogun+ 200 bar Spraying air 4 bars
Dynamic product pressure	120	140	200	140	200
K20	250	260	330	100	110
K30	320	350	420	110	120
K40	400	440	540	110	120
K50	580	600	780	120	130
K60	900	1000	1200	120	130
K70	900	1000	1200	120	130

**Note:** The hollow cone only gives good results at high product pressures; we do not recommend working below 140 bar. The best results are obtained between 160 and 200 bar.

**Note:** The spraying air pressure must be set between 2 and 3 bars (4 for the K70 gauge); below this, the spraying becomes less precise and above the jet becomes more dynamic and the hollow cone's benefits are reduced.

3.2.2. Version with whip (HR-MR)

**Flow limitation:**

The use of a whip limits the max flow available on the gun.

In the case of small gauges (up to 09 included) and for low viscosities (up to 40 sec CA4) the flow loss is around 15%. For larger gauges (12 and above) and for higher viscosities (above 40 sec and up to 80 sec), the flow loss is around 20% to 25%.

**Note:** for higher viscosities and very long hoses, above certain limits the flow starts to fall suddenly and becomes almost zero:

		Nanogun+ Airmix 120 bars + 15/1 pump					Nanogun+ Airmix 200 bars + 30/1 pump					
Injector		04	06	09	12	14	04	06	09	12	14	
		7.5 m + whip					7.5 m + whip					
Viscosity CA4	20	Prohibited					Prohibited					
	40											
	60											
	80											
	120											
			15 m + whip					15 m + whip				
	20	Prohibited					Not recommended					
	40											
	60											
	80											
	120											
			30 m + whip					30 m + whip				
	20	Prohibited					Prohibited					
	40											
60												
80												
120												

**Resistivity limitation (MR only):**

The use of a whip limits the low resistivity value to 2 MΩ.cm (0,5 for the standard version). However, if the application requires an electrostatic voltage lower than or equal to 45 kV, the product's min resistivity may be 1MΩ.cm.

**3.3. GNM 6080 Characteristics**

**Installation category II (according to EN 61010-1).**

General	
Weight	1.7 kg
Dimensions	Diameter: 168 mm
	Height: 91 mm
Operating temperature	0-40°C
GNM 6080 Input	
Voltage	88 - 264 V AC
Frequency	50 - 60 Hz
Max. current	0,25 A
Max. power	25 V.A
GNM 6080 output	
Voltage	40 V rms
Current	200 mA rms



The GNM 6080 automatically adapts to the supply voltage.

### 3.4. Operation

Pressing the trigger serves to delay the order to open the air valve, then activation of the high voltage, and lastly the paint nozzle needle. The high-voltage order may be inhibited by shifting the gun switch.

The **Nanogun+ Airmix**<sup>®</sup> gun is equipped with a magnetic sensor that detects the trigger position. This sensor serves to activate the high-voltage power supply once the air valve returns to a value lying between 1 and 1.8 mm.

- The button located in back of the gun does not serve to adjust the paint flow rate; nonetheless, it is possible to adjust it by modifying the nozzle gauge and/or the incoming product pressure.
- The side button serves to adjust the jet dimension within a range that narrows as the product pressure increases.
  - Clamped screw: large impact.
  - Loosened screw: reduced impact.
- In order to modify the jet dimension, it is necessary to change the nozzle.

### 3.5. For use

Paint Recommendations

Generally speaking, all paints and varnishes used with the conventional pneumatic guns are typically used with the **Nanogun+ Airmix**<sup>®</sup> gun as well. The dyes contained in the paint must be less than 5 mm.

#### 3.5.1. Viscosity

The best results are obtained with a viscosity ranging from 25 to 30 seconds, measured with AFNOR cup 4. However, paints with a lower or higher viscosity (for example 14 to 50 seconds or more) can be sprayed.

#### 3.5.2. Resistivity

Use a paint whose resistivity is suitable for the **Nanogun+ Airmix**<sup>®</sup> spray gun model that you are using. Optimum resistivity ranges from 0.5 to 500 MΩ.cm. Low resistivity promotes a good wraparound effect, but there may be back spray onto the operator if the booth is inadequately ventilated, especially when using the round spray.

Much lower resistivity (for example 0.1 MΩ.cm) will short circuit the high voltage and therefore prevent any wraparound effect. High resistivity (e.g. 1000 MΩ.cm) will significantly reduce the wraparound effect and will be greatly reduced. Paint resistivity can be easily checked using the **Sames AP 1000** resistivohmmeter.

#### 3.5.3. Settings of the spraying parameters

Regardless of the type of nozzle, the quality of spraying depends on both the supply pressure and the product viscosity: as viscosity increases, pressure must also rise, yet the final outcome is also influenced by the product's proportions of heavy solvent / light solvent.

A few key points:

- Viscosity: 40 sec CA4: minimum product pressure of 70 bar.
- Viscosity: 60 sec CA4: minimum product pressure of 90 bar.
- Viscosity: 90 sec CA4: minimum product pressure of 130 bar.

The addition of more air serves to reduce the impact width by 25% at a 120-bar pressure; moreover, the higher the product pressure, the smaller the influence being exerted by the additional air. In order to limit the production of overspray, it is recommended to never exceed an air pressure of 4 bar.

Using the nozzles with small impact width (XX-09 or 11), whenever the additional air is open, the jet is practically round.

Table of impact widths in water at a gun/part distance of 25 cm (closed to any additional air).

Nozzles	Impact width
03-05	12 cm
04-05	
03-07	17 cm
04-07	
04-09	21 cm
06-09	
09-09	
12-09	
14-09	
04-11	25 cm
06-11	
09-11	
12-11	
14-11	
04-13	29 cm
06-13	
09-13	
12-13	
14-13	
06-15	33 cm
09-15	
12-15	
14-15	
14-17	37 cm

## 4. Electric diagrams

### 4.1. Connection cable GNM 6080 / Nanogun+ Airmix®

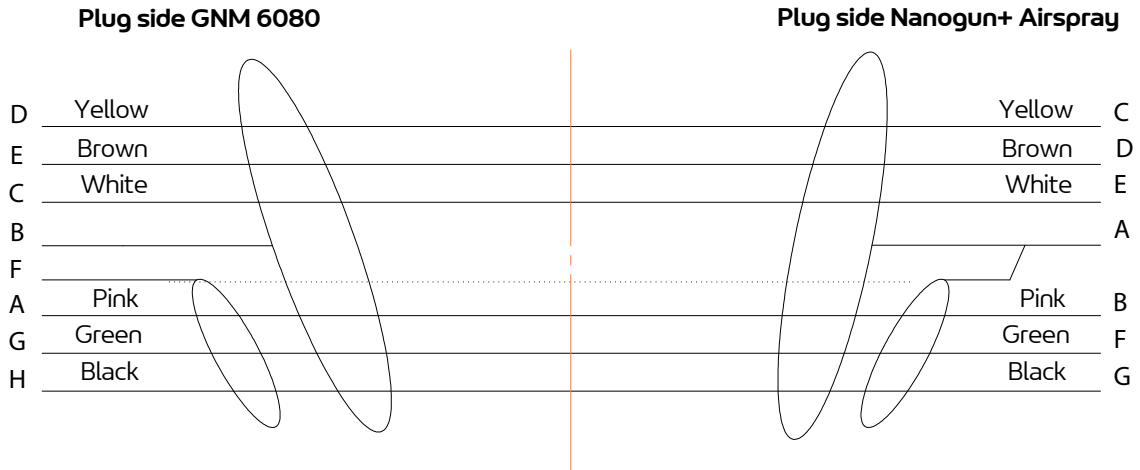

### 4.2. GNM 6080 trigger cable

A	Pink	Primary transformer HVU 3
B		Shield
C	White	REED sensor (trigger)
D	Yellow	Dallas chip
E	Brown	OV commun puce / reed
F		Third shield
G	Green	Primary transformer HVU 3
H	Black	Return IHV 1

Plug side GNM 6080

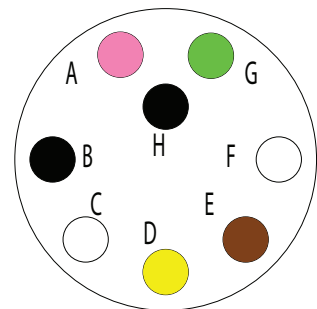

(\*)

**Switch "open": Nanogun+ Airmix® trigger releases.**  
**Switch "closed" : Nanogun+ Airmix® trigger activated.**  
**Characteristics of the switch: 0.5 A maxi / 24 VAC/DC maxi.**



## 5. Start-up

### 5.1. Tools

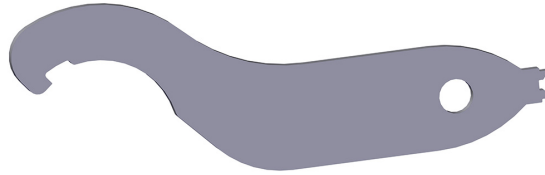

Part number	Description	Qty	Unit of sale
900012843	Multipurpose spanner	1	1



Part number	Description	Qty	Unit of sale
H1GMIN017	White vaseline (100 ml)	1	1
H1GSYN037	Dielectric lubricant for high voltage cascade and needle duct (100 g)	1	1

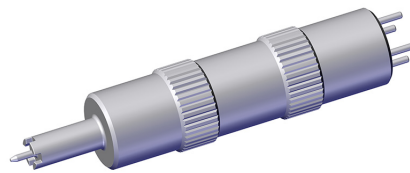

Part number	Description	Qty	Unit of sale
900010160	Cartridge and air valve assembly tool	1	1



Part number	Description	Qty	Unit of sale
240000301	Seal extractor tool	1	1



Part number	Description	Qty	Unit of sale
129400923	Air cap cleaning brush	1	1

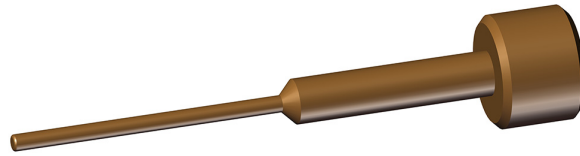

Part number	Description	Qty	Unit of sale
900016773	Supply pad removal tool (hollow cone)	1	1

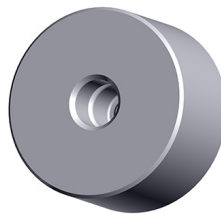

Part number	Description	Qty	Unit of sale
900016975	Rapid injector rinsing tool (hollow cone)	1	1

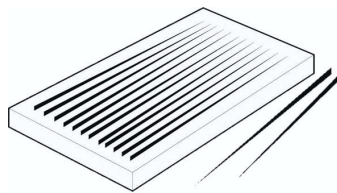

Part number	Description	Qty	Unit of sale
000094000	Unpluging needles for gauges 04 through 09	1	1 box (12)
000094002	Unpluging needles for gauges above 09	1	1 box (12)

**Additional tools and accessories required:**

The tools listed below should be available for product installation and maintenance operations.

- Flathead screwdriver (2.5x75; 4x100, 5.5x100)
- Phillip's screwdriver (0x75; 2x125)
- Allen keys (3 - 6 mm)
- Torque wrench 1 to 5 Nm (R.304DA Facom) (**Sames** P/N: 240000095)
- Open-ended spanners (5 - 5.5 - 15 - 17 - 18 - 21 - 24 - 27 mm)
- Socket wrench (socket diameters 4 and 13)
- Flat nose pliers
- Cutting pliers
- Ohmmeter

## 5.2. Using the multipurpose spanner

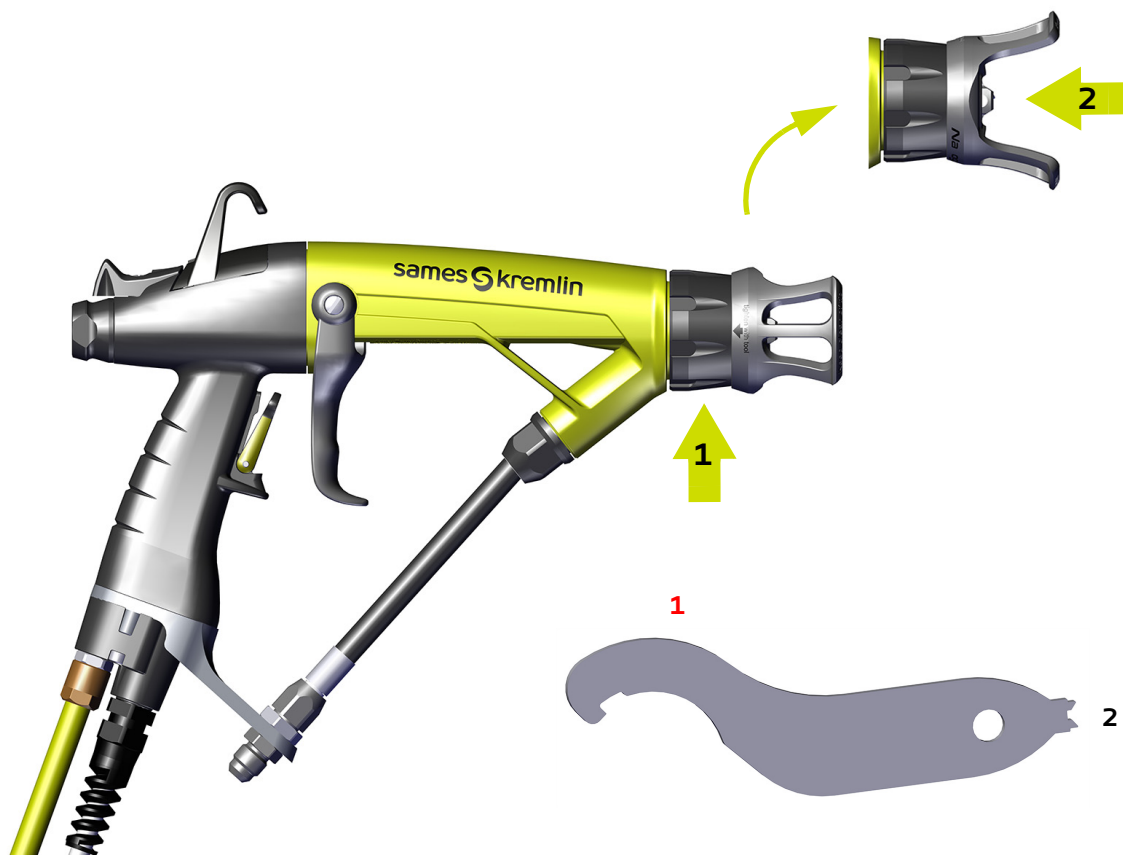

- 1 : Clamping of the air cap ring.
- 2 : Extraction of the head nozzle.

### 5.3. Installation

#### 5.3.1. With piston pump for all versions



Before any work, please refer to the installation rules ([see § 1.7 page 12](#)).

1	General air supply
2	Air filter
3	Main air valve
4	Pump air shut-off valve
5	Air pressure regulator
6	Spraying air filter/regulator
7	Spraying air valve
8	GNM 6080 control module
9	Spray gun air supply hose
10	<b>Nanogun+ Airmix®</b> Spray Gun
11	Low voltage power supply cable
12	Pump (complies with ATEX Directive)
13	Dump valve
14	Product filter
15	Product supply hose
16	Mains power cable (220V + ground) or (115V + ground)
17	Warning sign
18	Potentially explosive atmosphere
19	Area with no risk of explosion

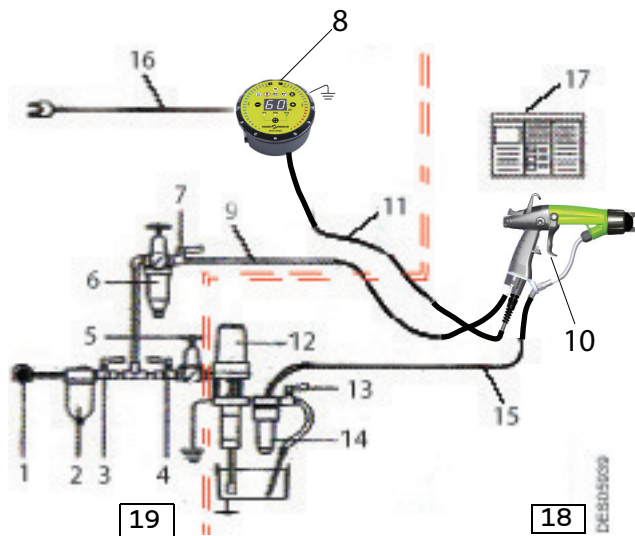

The paint supply must be installed in a well-ventilated area.

The paint container and pump must always be electrically grounded.

The dump hose must be submerged in the paint.



**The paint supply pump:**

- must feature a maximum ratio of 19:1 for the 120-bar version and of 30:1 for the 200-bar version;
- and the pump's air inflow must be equipped with a safety relief valve to limit pressure to a maximum value of 6.5 bar.

## 6. Maintenance

Preventive maintenance is an essential part of production and ensures the reliability of the installation. As a reminder, the performance of equipment can only be guaranteed if a minimum of control and cleaning operations are performed on this equipment.



**Soiling and wear of the Nanogun+ Airmix<sup>®</sup> gun depend on the operating and application conditions and the production rates.**

### 6.1. Summary table of maintenance operations

The maintenance intervals indicated in the procedures below are only indicative. The user will have to create his own maintenance schedule as he use **Sames** equipment.

Carry out when the maintenance indicator light of the **GNM 6080** is ON.

Procedure		Detail	Duration	Frequency
<b>Cleaning</b>				
<b>A</b>	<b>A1</b>	Cleaning the product circuit	10 min.	Once a day
	<b>A2</b>	Cleaning the spray gun	10 min.	Once a day
	<b>A3</b>	Hollow cone nozzle cleaning	10 min.	Once a day
	<b>A4</b>	Waste disposal	5 min.	Once a day
	<b>A5</b>	Demolition and Recycling	5 min.	Once a day
<b>Replacement</b>				
<b>B</b>	<b>Paint circuit</b>			
	<b>B1</b>	Replacement of the paint hoses	10 min.	2000 hours
	<b>B2</b>	Replacement of the spray head assembly	5 min.	1000 hours
	<b>B3</b>	Replacement of the electrode located in the air cap	5 min.	1000 hours
	<b>B4</b>	Replacement of the paint needle	5 min.	2000 hours
<b>C</b>	<b>Barrel</b>			
	<b>C1</b>	Replacing the seals cartridge	10 min.	2000 hours
	<b>C2</b>	Replacement of the air valve	5 min.	2000 hours
	<b>C3</b>	Replacement of the high voltage cascade	20 min.	-
<b>D</b>	<b>Handle</b>			
	<b>D1</b>	Replacement of the handle	20 min.	2000 hours
	<b>D2</b>	Replacement of the electropneumatic coupling	5 min.	4000 hours
	<b>D3</b>	Replacement of the switch	20 min.	4000 hours
	<b>D4</b>	Replacement of the trigger	5 min.	1000 hours
	<b>D5</b>	Replacement of the fixing hook	5 min.	4000 hours

## 6.2. Preventive maintenance plan - PMP 7115

[see § 11.1 page 87](#)

The objective of the proposed preventive maintenance plan is to define in an exhaustive way, the verification, replacement and cleaning actions of the installed **Sames** equipment.

In order to anticipate breakdowns and malfunctions that may be due to technical deviations of the installation, the preventive maintenance plan attached to the user manual lists the routine maintenance operations necessary for better comfort in the use of the production tool.

Depending on the skills, area of responsibility and accreditation of each person involved, the preventive maintenance plan can be divided into two distinct levels: level 1 and level 2:

- **Level 1:** first level maintenance is essentially composed of visual control and cleaning operations of some elements of the equipment. To limit this level, only the specific tools supplied with the equipment will be used. This first level of maintenance is generally taken care of by paint operators or installation managers.
- **Level 2:** second level maintenance completes the first level by more complex dismantling operations requiring electrical engineering tools.  
This second level is generally handled by the factory maintenance department.

## 6.3. Cleaning

Always refer to the health and safety instructions before carrying out any work on the spray gun ([see § 1 page 7](#)).



**Always wear safety glasses.**

**When handling solvents, wear gloves of a suitable resistant material.**



**Work in a well ventilated area when using solvents.**



**Before any maintenance work on the spray gun, always refer to the health and safety instructions ([see § 1 page 7](#)):**

- **Disconnect the control module from the power supply.**
- **Check that the air and paint circuits are not pressurised.**
- **Dump the paint circuit.**

### 6.3.1. Procedure A1 : Cleaning the product circuit

- Disconnect the **GNM 6080** control module.
- Install a bucket of solvent in place of the paint container.
- Open the recirculation valve to clean the pump.
- Close the recirculation valve and hold down the trigger until clean solvent comes out of the spray gun nozzle/tip.

### 6.3.2. Procedure A2 : Cleaning the spray gun

The spray gun must be cleaned immediately after use and at the end of the day, as with all paint guns. The cleaning procedure described below should be followed carefully:



**It is formally forbidden to plunge the Nanogun+ Airmix<sup>®</sup> into solvent.**

**Utiliser un solvant approprié: solvant non gras, de résistivité élevée et non chloré.**

- Step 1:** Disconnect the **GNM 6080** control module.
- Step 0:** Depressurise the spray gun air circuit.
- Step 3:** Dump the spray gun paint circuit and rinse with an appropriate solvent ([see § 1.9 page 15](#)).
- Step 4:** Depressurise the spray gun paint circuit.
- Step 5:** Dry the spray gun air cap with a soft, dry, lint-free cloth.
- Step 6:** Unscrew the spray gun air cap ring and remove the air cap ([see § 8.1.4 page 67](#)).
- Step 7:** Clean the air cap with a solvent-dampened brush and then wipe dry.
- Step 8:** Reassemble the air cap and ring.
- Step 9:** Dry the compressed air spray gun (facing downwards) before restarting the **GNM 6080** control module.



**Never disassemble the needle assembly when the paint hose contains paint or solvent.**



**When cleaning the nozzle/tip, always point the spray nozzle/tip towards the ground to prevent solvent or paint from flowing into the barrel ducts.**



**After cleaning, the ducts and supply hose must be dried with compressed air to remove all traces of solvent.**

### 6.3.3. Procedure A3: Hollow cone nozzle cleaning

It is vital to clean the spraying head fully at the end of each shift or when use is interrupted, depending on the type of product between 5 and 30 minutes.

#### Cleaning procedure:

- **Step 1:** Disconnect the air and high voltage supplies. Engage the safety catch (A) on the trigger.



- **Step 2:** Loosen the cap nut, retrieve the cap and the low cone and plunge them into a solvent bath for a few minutes then clean them with a clean cloth.

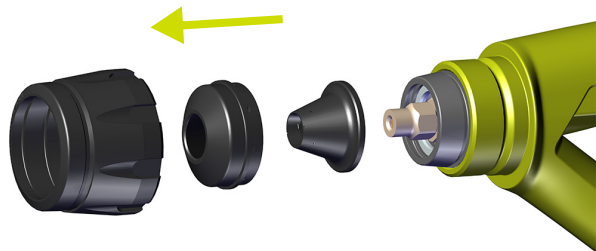

- **Step 3:** Using an 11 flat wrench, unscrew the injector, leave to soak in the solvent then clean with a clean cloth and a soft brush.

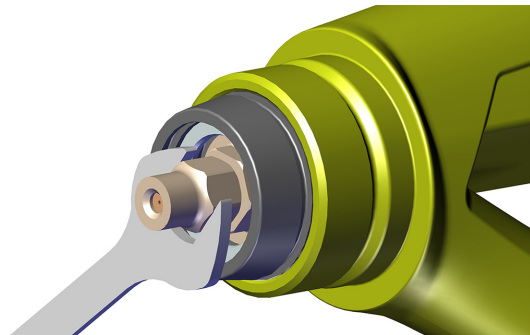

- **Step 4:** Screw the placebo (B) injector fully in place by hand. Remove the safety catch and dump the circuit.

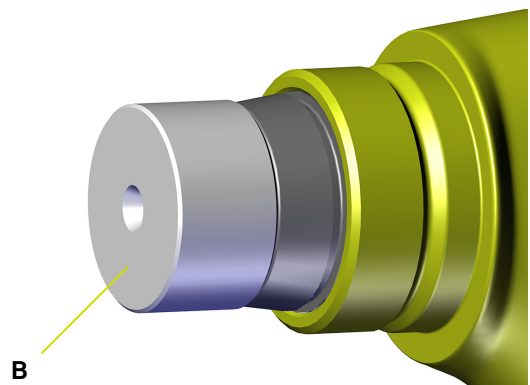



## Reassembly

- **Step 5:** Remove the placebo injector.
- **Step 6:** Coat the rear part (threading / seal) of the dielectric grease injector.
- **Step 7:** Add more and/or put back the dielectric grease on the HV contact. Coat the external thread of the barrel with dielectric grease.
- **Step 8:** Put the internal cone and the cap back in place. Tighten the cap nut.

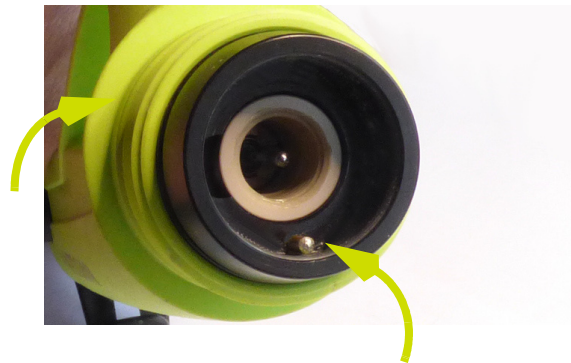
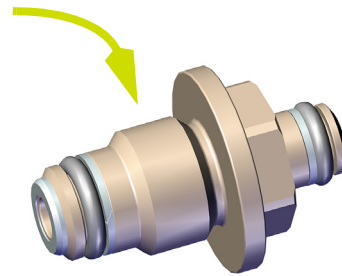

### 6.3.4. Procedure A4: Waste disposal

Waste generated by use of the apparatus (spent solvent, unused paint, residue, dirty cloths, paint booth slurry, water-wash spray booth run-off, used dry filters, ventilation air etc.) must be removed, transported and disposed of in strict compliance with the applicable local regulations.

6.3.5. Procedure A5: Demolition and Recycling

6.3.5.1. Nanogun+ Airmix®



All the parts can be contaminated by paint residues and/or of solvent. Before proceeding to the demolition of the equipment, clean the spray gun and more particularly the inside of paint hoses with an appropriate cleaning product and air-drying them with compressed air.

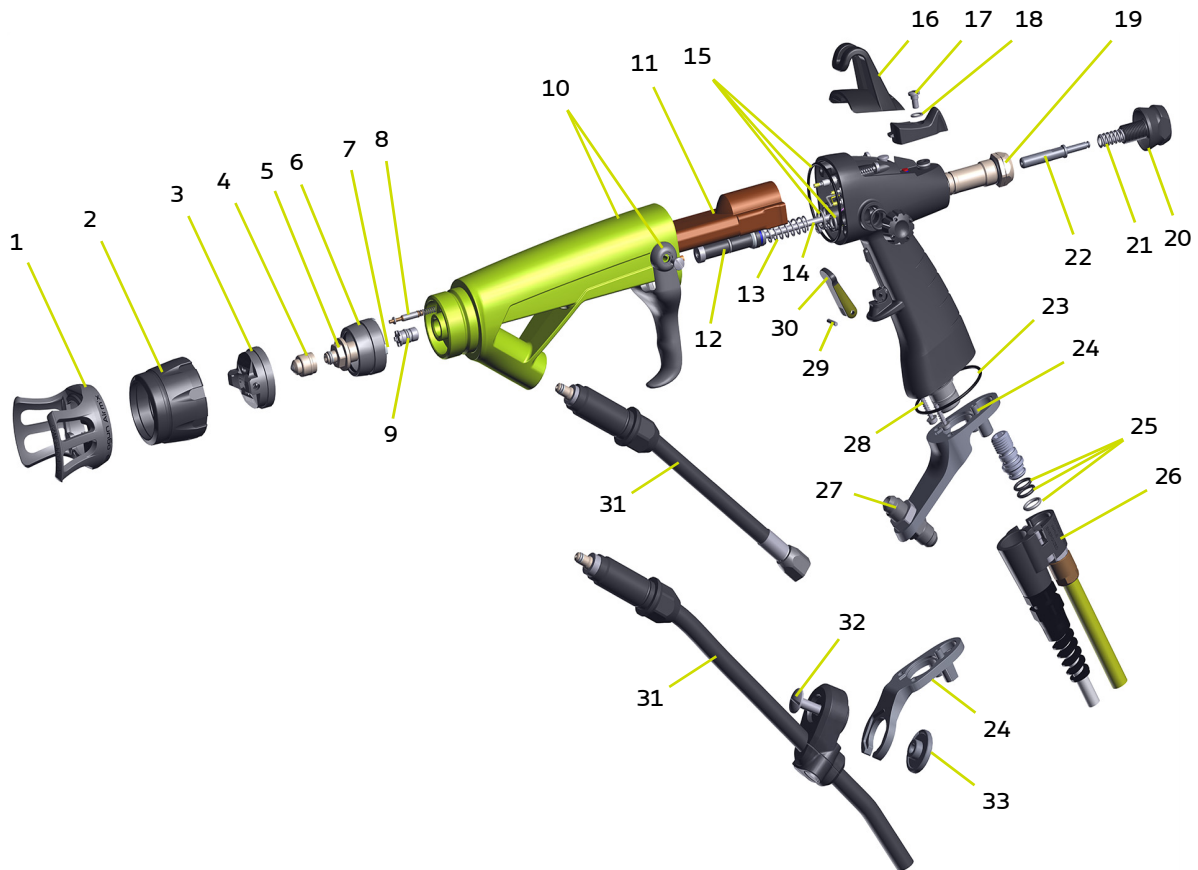

Rep.	Material
1	Polypropylene not containing with glass fibre
2, 6*	POM C, PTFE, chemically inert rubber
3	Plastic material containing glass fibre, PTFE, stainless steel
4	PEEK, tungsten carbide, PTFE, stainless steel
5*	PEEK, chemically inert rubber, stainless steel
7*	PTFE
8*	Brass, agglomerated carbon
9*	Stainless steel, chemically inert rubber, PTFE
10*	Plastic material containing fibre, PEEK
12	Loaded PEEK, chemically inert rubber, PTFE
15, 18, 25	Chemically inert rubber
31*	Stainless steel, PTFE, polyurethane, aramid, PEEK, chemically inert rubber
11, 14*	Plastic material, copper, steel, ceramic, ROH electronic components,
22*	Tungsten, PEEK, stainless steel, aluminium

13*, 21*, 17, 34, 26, 27, 28, 29, 32, 33	Stainless steel
16	Plastic material containing fibre
19*	Plastic material, chemically inert rubber
20*, 24	Aluminium
23	Rubber
26	Plastic material containing fibre, copper, stainless steel
33	Fibre joint
30	Polyamide not loaded
Not represented	Air hose: PU
Not represented	Product hose: PTFE - aramid - PU Couplings: Zinc-plated steel or stainless steel Cable gland: plastic material containing fibres

**\* These parts (5, 6, 7, 8, 9, 10, 13, 14, 19, 20, 21, 22, 31) may be fouled due to dielectric grease.**

### 6.3.5.2. GNM 6080

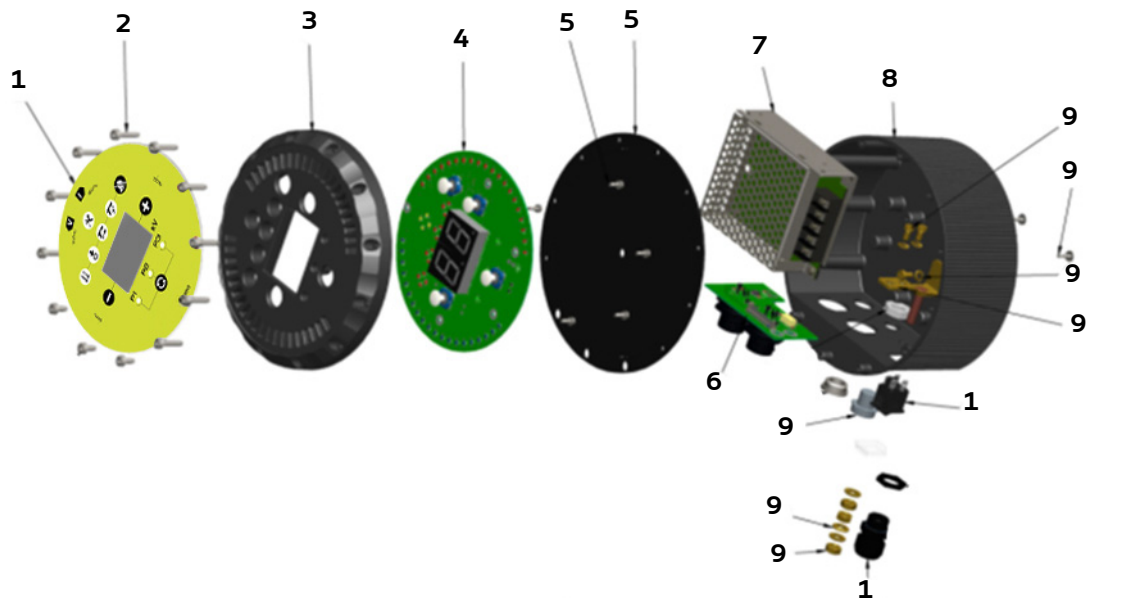

Item	Description	Material
1	Keyboard / front face*	Plastic
2	Fastening screw of front face	Stainless steel
3	Support of main board and front face	Aluminium
4	Main board	Electric and electronic components, printed circuit ROHs
5	Rear metal sheet and fastening screw	Steel
6	Connector board	Electric and electronic components, printed circuit ROHs
7	Electric power	Electric and electronic components, printed circuit ROHs
8	Box	Aluminium
9	Fixation accessories	Steel and brass
10	Electric switch	Electric component ROHs
11	Stuffing box	Plastic
<b>Not shown</b>		
12	Power cable	Plastic and copper

\* Attention, this component can be soiled with dielectric grease.

## 6.4. Replacement

### 6.4.1. Procedure B1: Replacement of the paint hoses

#### 6.4.1.1. Paint hose - Version QD (HR)

- **Step 1:** On the handle side, unlock the fitting (A) with a 15 flat wrench and then unscrew the lock nut (B) with a 17 flat wrench.

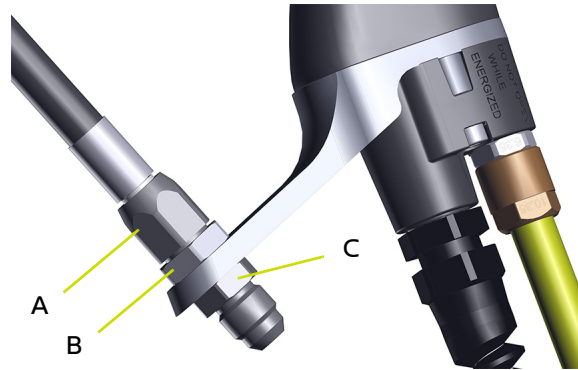

Unscrew the nut (C) with a 15 flat wrench until the fitting (A) is free without deforming the paint hose

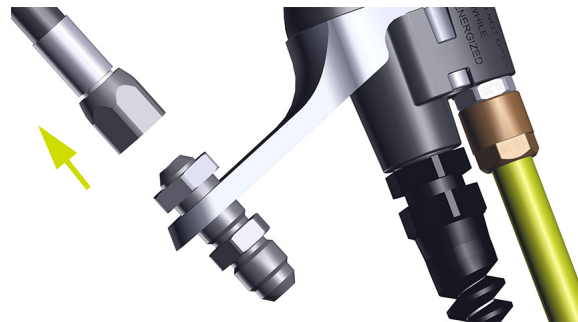

- **Step 2:** Using a 21 flat wrench, unscrew the upper nut on the paint hose, and then finish the unscrewing manually while holding the lower nut.
- **Step 3:** Check that the O-ring is on the paint nut. Verify the presence of this O-ring (P/N # J3STKL028) and the anti-extrusion ring (P/N # 910013398) on the paint hose. In the event both the O-ring and ring need to be removed, they must be replaced by new ones.



**For the reassembly step, proceed in the reverse order. Screw the upper nut on the paint hose until reaching its stop point.**

## 6.4.1.2. Paint hose LR-MR

- **Step 1:** Unscrew the two screws (**B**) of the flange (**A**) and take out the paint hose.

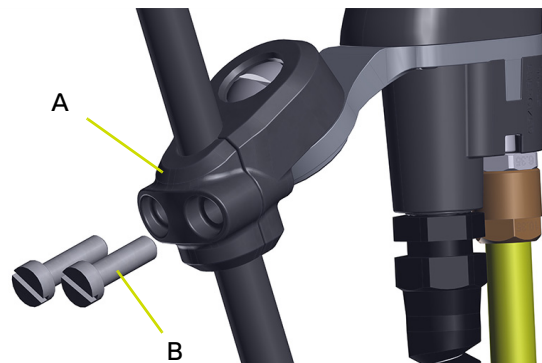

- **Step 2:** With a 21 flat wrench, unscrew the upper nut on the paint hose. Unscrew the nut while turning the hose.



**For the reassembly step, screw the upper nut on the paint hose until reaching its stop point. Position the locknut of the stuffing box below the bracket, with the stuffing box above in the hexagonal imprint. Clamp the locknut of the stuffing box onto the bracket.**

### 6.4.2. Procedure B2: Replacement of the spray head assembly

- **Step 1:** With the multipurpose wrench (P/N # 900012843), unscrew the air cap ring.



- **Step 2:** Extract the head nozzle using the multipurpose wrench. Do not use your fingers.



**WARNING:** It is imperative to replace the sieve or the sealant seal each time the nozzle is removed ([see § 8.1.3 page 66](#)).

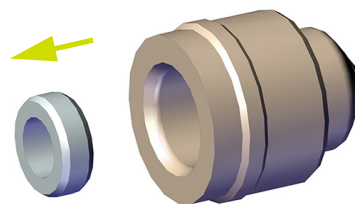

- If necessary, replace the head seal.

For the reassembly step, proceed in the reverse order.



### 6.4.3. Procedure B3: Replacement of the electrode located in the air cap

#### Disassembly:

- **Step 1:** Pull out the conductive PTFE washer. Using one of the two housings on the back of the air cap, insert the screwdriver blade under the washer (do not use the housing where the centering pin is located). Make a slight turning motion with the screwdriver and proceed in the same manner with the second housing. Remove the washer by hand.

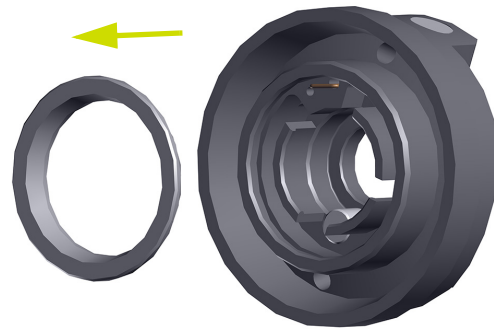

The rear part of the electrode is visible.

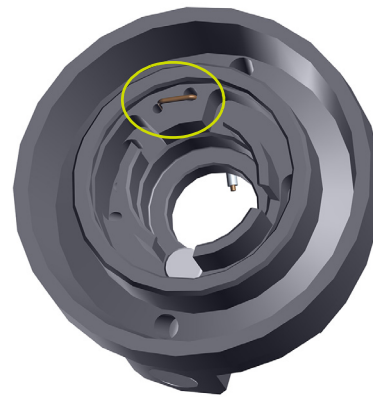

- **Step 2:** Straighten the electrode vertically with the flat pliers.
- **Step 3:** Push the electrode toward the back of the air cap. When the electrode is sufficiently pulled out, remove it from the back with the flat pliers.

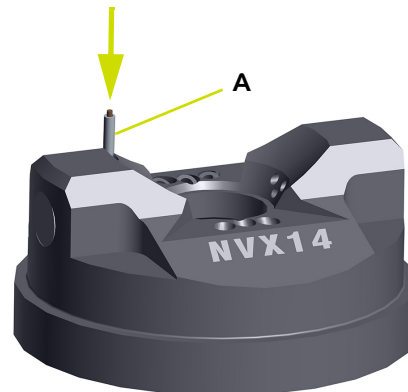

- **Step 4:** With the flat pliers, remove the small PTFE tube surrounding the electrode. Check that no residue remains in the electrode housing. If necessary pass by hand, a drill or a 1 mm metal rod into the hole.

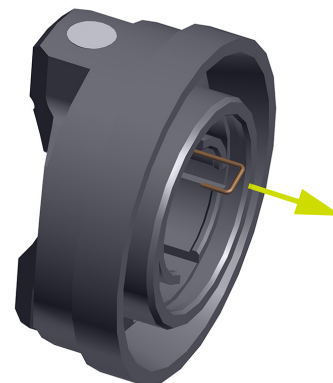

**Reassembly:**  
**The repair kit includes an electrode equipped with its small PTFE tube.**

- **Step 1:** If necessary, clean the electrode manually and with precaution with a drill or metal rod of 1mm diameter

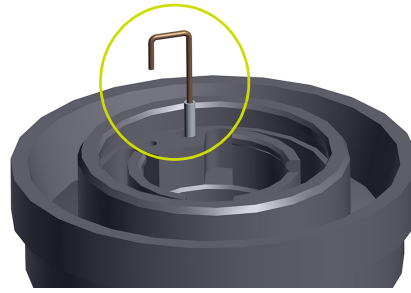

- **Step 2:** Insert the electrode equipped with the PTFE tube. As soon as it appears on the other side of the air cap, pull it with fingers. Then push it to the bottom of the housing with the screwdriver, the return strand of the electrode must fit into a small bore, only the rear part of the electrode must flush with the bottom of the counterbore.

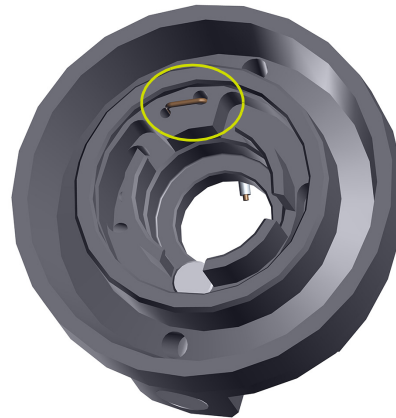

- **Step 3:** Clip the PTFE conductive washer. Replace it if necessary. It is advised not to reuse it more of 3 or 4 times, the washer should not be able to be removed without the use of a tool.

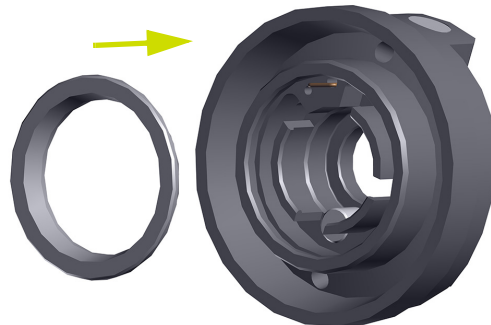

- **Step 4:** Check the continuity between the conductive PTFE washer and the metal end of the electrode. The usually measured value is of the order of 200 to 300  $\Omega$  but a value up to 1000  $\Omega$  is admissible.

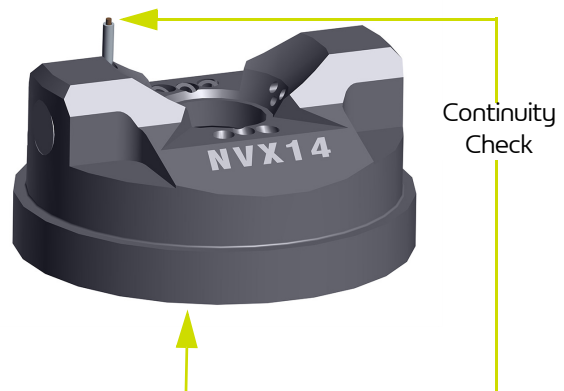



- **Step 5:** Fold the electrode with the flat pliers and cut to about 5 mm.



**WARNING:** The small PTFE tube must not mask the end of the electrode, cut it if necessary. On the other hand the metallic end can be a little discovered (less than 1mm).

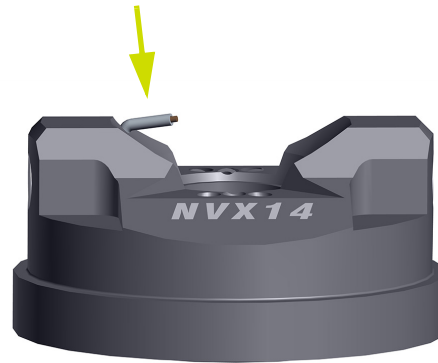

**WARNING:** The electrode must not be in contact with the injector when the air cap is mounted on the gun.

#### 6.4.4. Procedure B3: Replacement of the paint needle

- **Step 1:** Unscrew the notched button (A) at the rear of the spray gun, retrieve the spring (B).

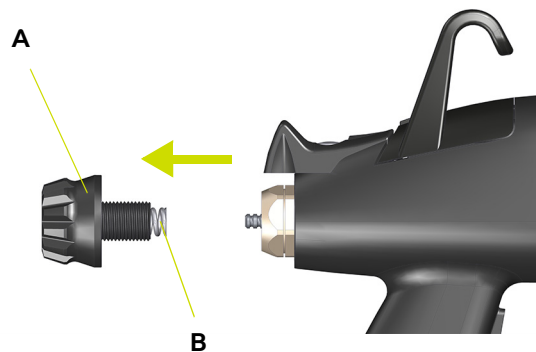

- **Step 2:** Press the trigger and pull manually the paint needle towards the back.

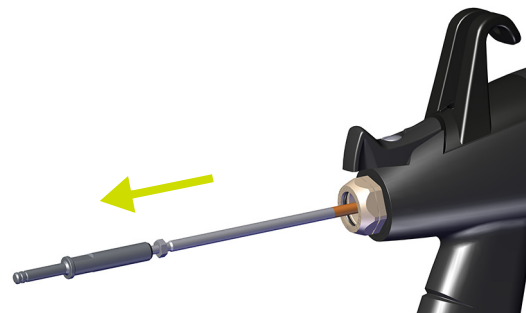

To reassemble, follow the steps in reverse order.



Every 4 or 5 reassemblies, add some dielectric grease (Ref.: H1GSYN037) in the passage channel in the barrel.

#### 6.4.4.1. Setting the paint needle

- **Step 1:** Remove electro-pneumatic coupling and product hose to the gun base.

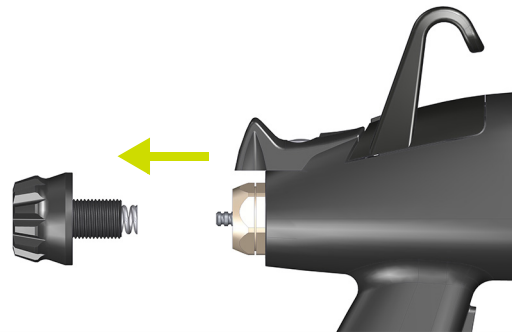

- **Step 2:** Remove rear nut with paint spring

- **Step 3:** To ensure the needle is in contact with the seat nozzle (rest position), push it with your finger.

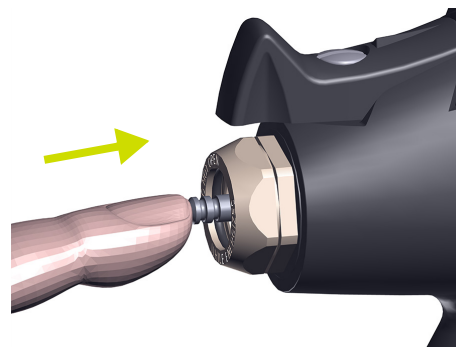

- **Step 4:** Considering that the needle is in contact with the seat nozzle, the length which is sticking out the rear nut should be used as initial position with a caliper (set at "000").

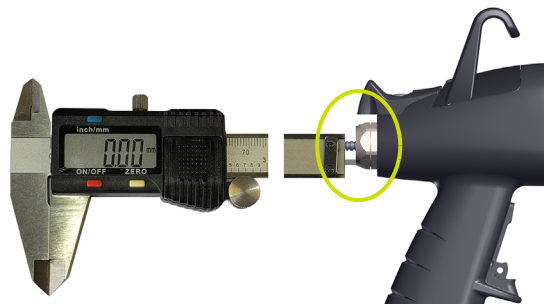

- **Step 5:** Press the trigger to extreme position in order to push back the needle to max rear position. Keep this position to measure needle's stroke.

- **Step 6:** The value must be between 1.8 mm and 2.2 mm. If the value is not between the acceptable range, go to step 7. If the value is between the acceptable range, go directly to step 8.

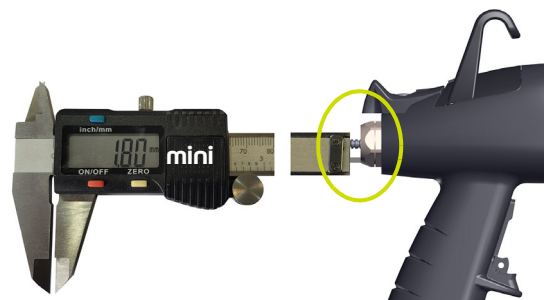

- **Step 7:** Pull the needle out of the gun to adjust its length.

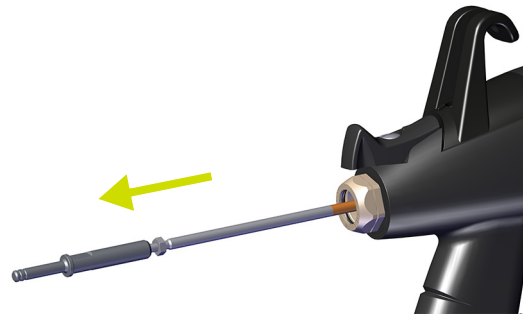

Untighten the nut (**B**) to allow the adjustment procedure.

- If the value on **step 6** is under 1.8 mm, untighten the needle rear stop (**A**) to increase the needle length.  
For information: One turn = 0.5 mm.  
Tighten again the nut (**B**) to lock the needle length and check again the value according to **step 6**.

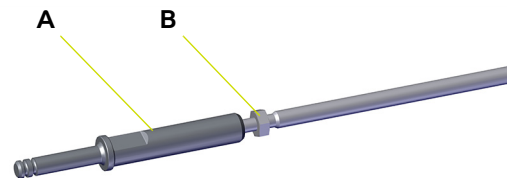

- If the value on **step 6** is over 2.2 mm, tighten the needle rear stop (**A**) to reduce the needle length.  
For information: One turn = 0.5 mm.  
Tighten again the nut (**B**) to lock the needle length and check again the value according to step 6.

- **Step 8:** Re-install the rear nut living 2 mm to 2.5 mm gap.

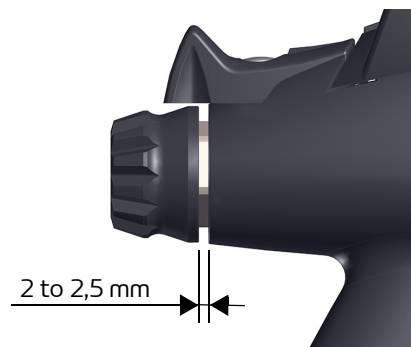

### 6.4.5. Procedure C1: Replacing the seals cartridge

#### Replacing the seals cartridge on the spray head side

- **Step 1:** Unscrew the seat casing using a 13-mm pipe wrench.

Then remove it.

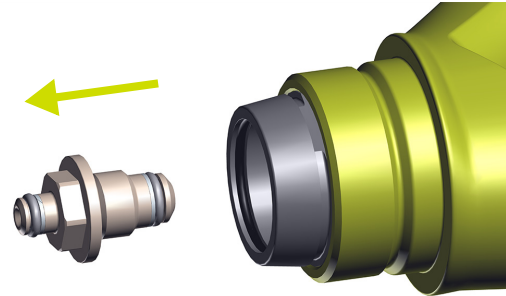

Should the O-rings and anti-extrusion rings located in front and back of the nozzle require replacement, remove them using a screwdriver, position the new rings and new seals in place while double checking their correct location and after coating them first with Vaseline.

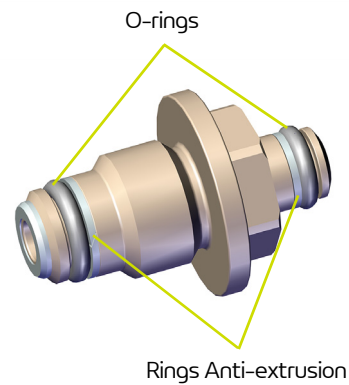

- **Step 2: Seal cartridge:** Unscrew the cartridge using the tool (P/N # 900010160).

Should the ring and external seal require replacement, remove them using a screwdriver, position the new ring and new seal in place while double checking their correct location.

**Note: The lip seals located inside the cartridge cannot be changed.**

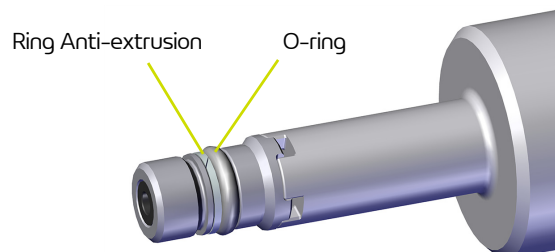
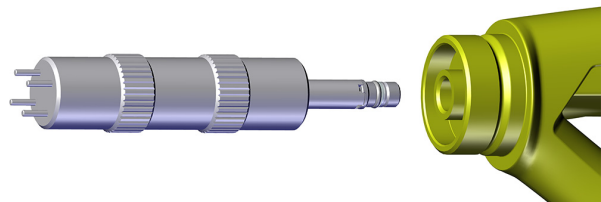

- **Step 3:** Manually remove the adapter equipped with its joint (A) and high-voltage resistance by its spring (B) and pulling on it.



**WARNING:** Be careful not to damage the resistance during its extraction.

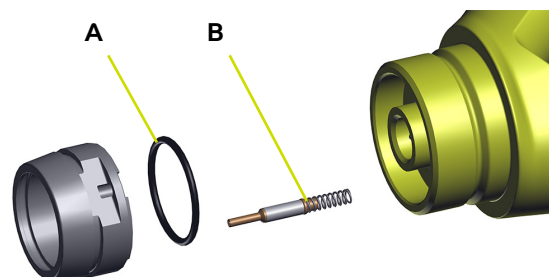

## Replacement of the seals on the handle side

- **Step 1:** Remove the trigger [see § 6.4.11 page 56](#), and the paint needle.
- **Step 2:** Unscrew the four screws fastening the barrel on the handle.
- **Step 3:** Unscrew manually or with a small flat pliers the three connection wires of the high voltage unit, pull carefully the contacts towards the back.

- **Step 4:** Replace the o-rings (B) of the air ducts and the air valve (**Step 3: not obligatory**): Remove and replace the three o-rings.

- **Step 5:** Replace the o-ring barrel/handle (A) (**Step 3: obligatory**): Remove and replace the o-ring. Replace this o-ring every year.

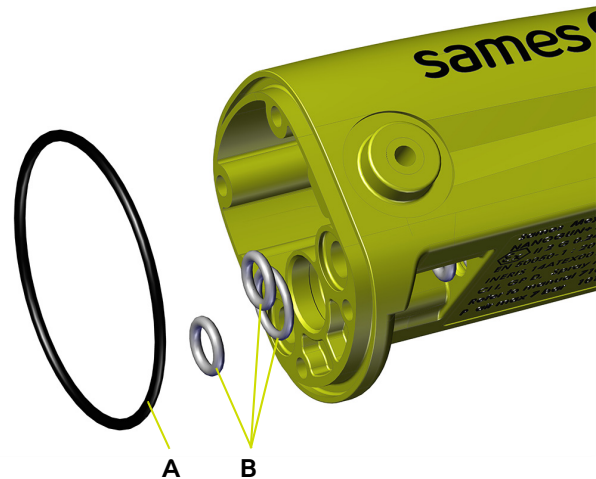

- **Step 6:** Replace the o-ring back of paint needle (C). Remove and replace the o-ring.

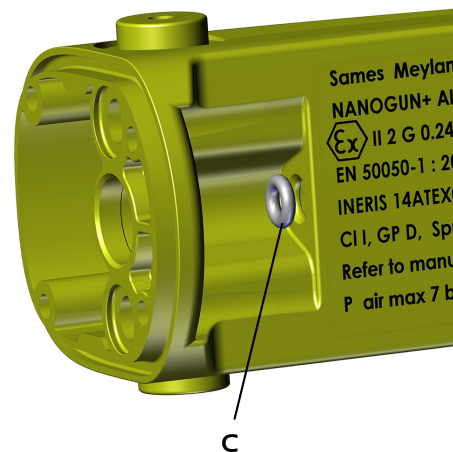

**To reassemble, follow the steps in reverse order.**

### 6.4.6. Procedure C2: Replacement of the air valve

- **Step 1:** Remove the paint needle ([see § 6.4.4 page 45](#)).
- **Step 2:** Unscrew the air valve stop nut using a 18 mm open-ended spanner.

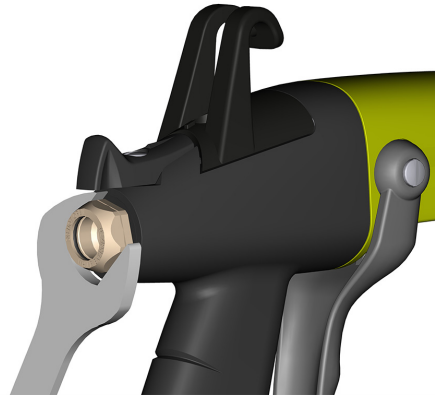

Position the gun barrel to the top and recover the spring and the air valve. If the parts do not fall, tap in the palm of the hand.

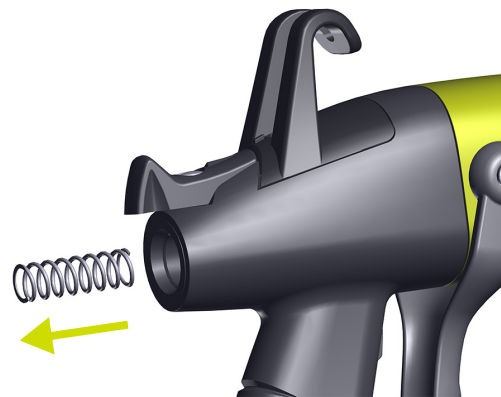

or use the paint needle to extract the air valve.

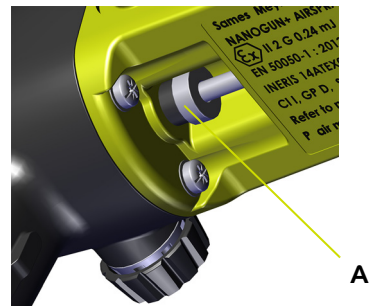
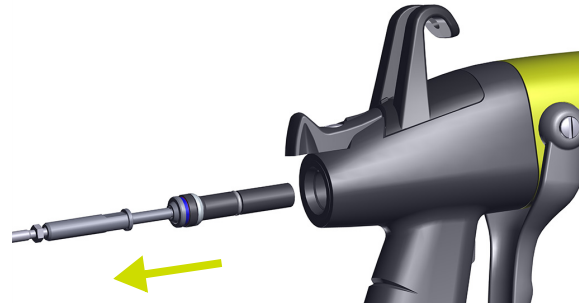

It is important to retrieve the shoulder washer (A) when removing the paint pin so that it does not get lost.

When reassembling, it is imperative to observe the mounting direction of the shoulder washer (A) as shown in the illustration.

### 6.4.6.1. Repairing the air valve

**Three levels** of maintenance are possible:

- **Level 1:** Standard level of maintenance because the body of the air valve does not undergo any friction nor wear.
- **Level 2:** Corrective maintenance, carry out if the valve body is damaged.
- **Level 3:** Exceptional maintenance, carry out if the magnet is lost or broken.

**Level 1: Replacement of the three o-rings** (P/N J3STKL032 inner ring **(A)**, J3STKL005 outer ring **(B)** and 900010256 conical seal **(C)**).

- For three seals, extract the old by taking care of not damaging the body of the air valve (but they can be destroyed).
- The conical seal must be pushed up to its click-and-ratchet work on the body of the air valve by taking care not to damage its conical reach.

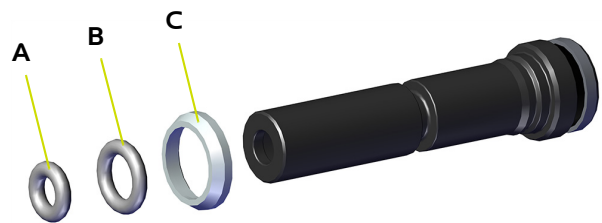

**Level 2:** If the valve body is damaged.

- Extract manually the aluminium ring **(D)** or put a M4 screw in the ring, pull out in the axle of the part, and remove the magnet by taking care to locate its direction (silver face on the ring side).
- Put in place the magnet **(E)** in the right direction and retain the ring in the body of the air valve by pushing firmly with the finger.

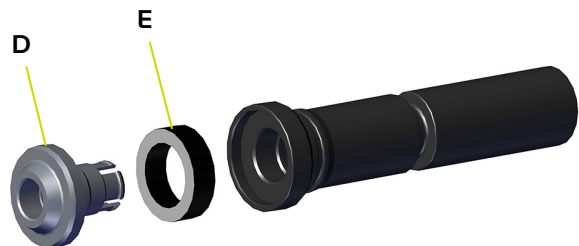

**After complete reassembly of the spray gun**, check the activation and the stop of the high voltage. If the high voltage is permanently engaged or does not cut itself: check the direction of the magnet.

**Level 3:** If the magnet is broken or lost.



**For this maintenance operation, it is recommended to contact Sames.**



### 6.4.7. Procedure C3: Replacement of the high voltage cascade

- **Step 1:** First, remove the trigger ([see § 6.4.11 page 56](#)), remove the paint needle ([see § 6.4.4 page 45](#)) and the fixing hook ([see § 6.4.12 page 57](#)).

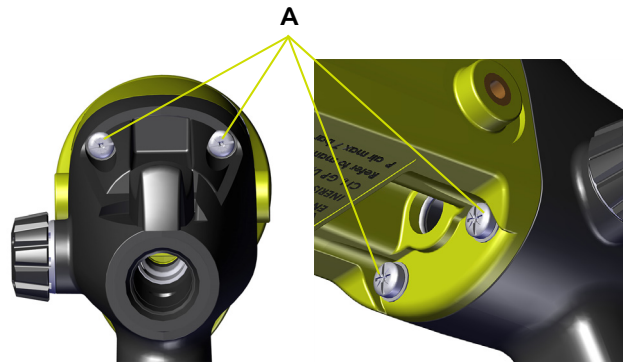

- **Step 2:** Loosen the 4 screws (**A**) fastening the barrel on the handle with a 2mm Phillips screwdriver.

- **Step 3:** Unscrew, manually or with a small flat pliers, the three connection (**B**) wires of the high voltage unit, pull carefully the contacts towards the back.

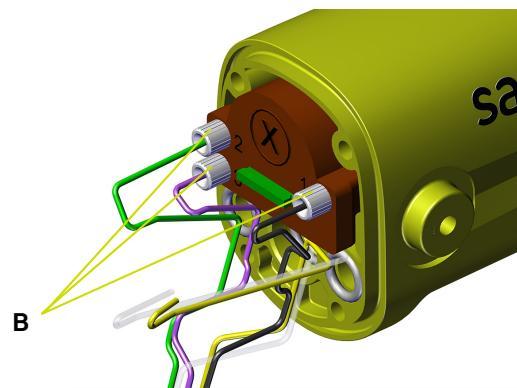

- **Step 4:** Remove the high voltage contact in front of the barrel ([see § 6.4.5 page 48](#)). Withdraw the high voltage unit.

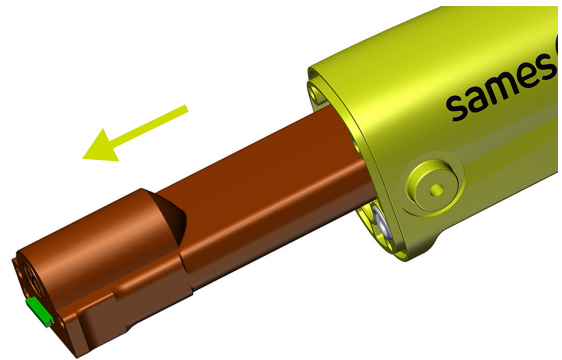

**WARNING :** Attention with the colors (terminal 1: black, terminal 2: green, terminal 3: pink).

**To reassemble, follow the steps in reverse order.** Replace the high-voltage cascade. **Coat the cascade with dielectric grease** (P/N # H1GSYN037) then insert it into its housing. Push the cascade fully into the barrel. Connect the three wires and tighten the screws. Check the wear of the o-rings, replace if necessary.

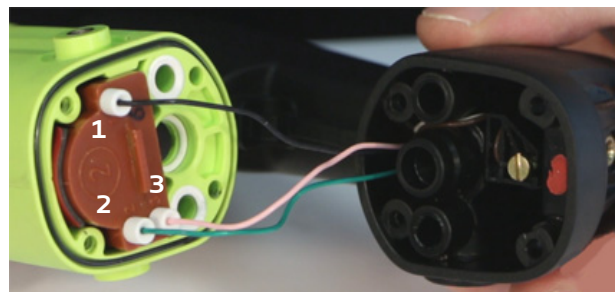



### 6.4.8. Procedure D1: Replacement of the electropneumatic coupling

- **Step 1:** Separate the barrel from the handle.

- **Step 2: Handle base**

Unscrew the air nipple using a 6mm allen key.  
Replace the seals every 12 months.

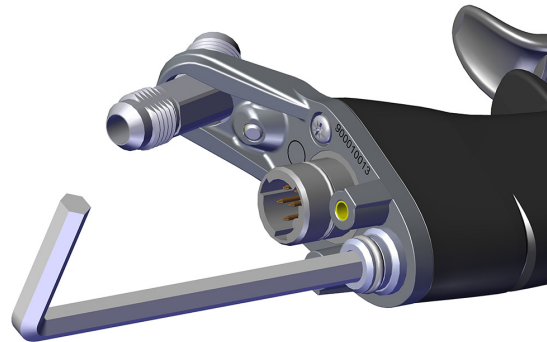

- **Step 3:** Undo both K35 x 14 screws with a 2mm Phillip's screwdriver. Change the fibre washers each time the screws are removed.

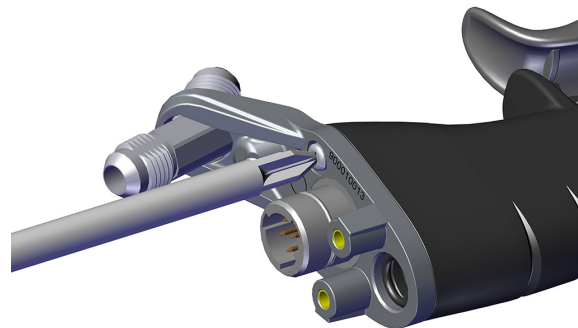

- **Step 4:** Lift the base to access the handle base seal. This seal should be replaced every 12 months.

- **Step 5:** Push the electrical connector to release it and remove from the base.  
Replace the seal of the connector every 12 months.

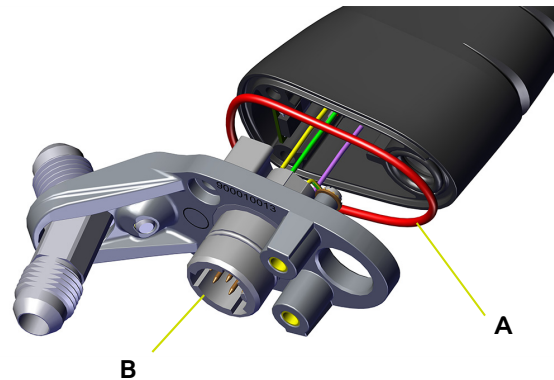

- **Step 6: Replacement of the base:** unscrew the screw of the ground wire using a 0 Phillip's screwdriver, withdraw it and replace it.

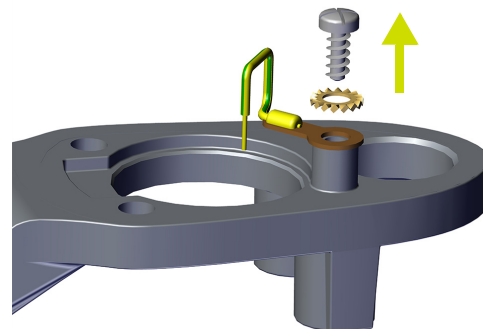

**To reassemble,** follow the steps in reverse order.  
Insert the connector pin back into the base foolproofing slot.  
Coat the air nipple seals with dielectric lubricant.  
Tighten the air nipple to 1.5 N.m torque.  
Tighten the two K35 x 14 screws to 1.3 N.m torque.

6.4.9. Procédure D2: Remove paint hose. Loosen the paint hose nut with a 15mm open-ended spanner.

6.4.9.1. HR version



**WARNING:** Do not remove the cable gland from the electrical cable..

- **Step 1:** Remove the paint hose.  
Unlock the fitting (A) with a 15 flat wrench and then unscrew the lock nut (B) with a 17 flat wrench

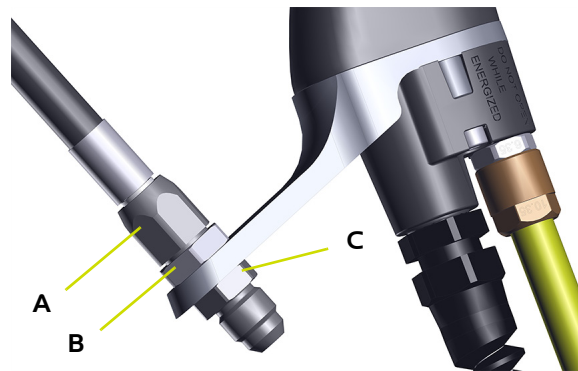

Unscrew the nut (C) with a 15 flat wrench until the fitting (A) is free without bending the paint hose.

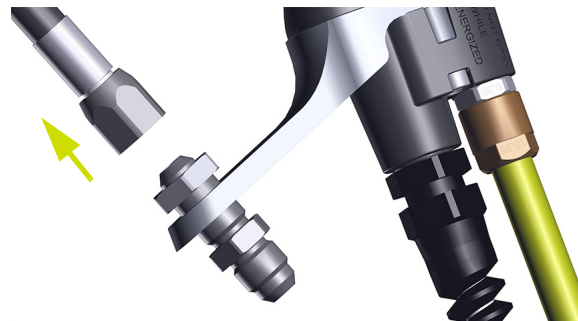

- **Step 2:** Unscrew the two captive screws of the electro-pneumatic coupling, with a 3 Allen wrench.

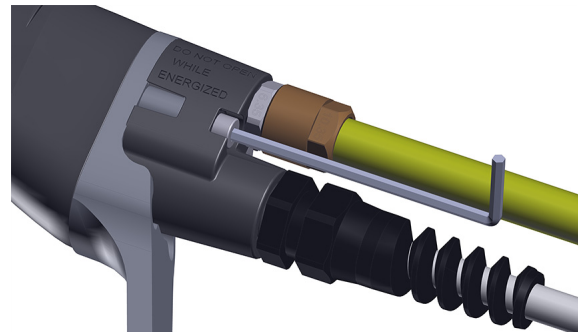

- **Step 3:** Disconnect the electro-pneumatic coupling by pulling on it.

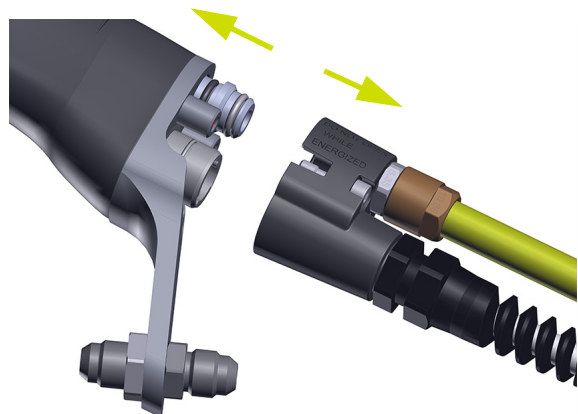

**To reassemble, proceed in reverse order.**

6.4.9.2. LR - MR versions



**WARNING:** Do not remove the cable gland from the electrical cable.

- **Step 1:** Remove the paint hose. Unscrew the two screws (B) of the flange (A) and take out the paint hose.

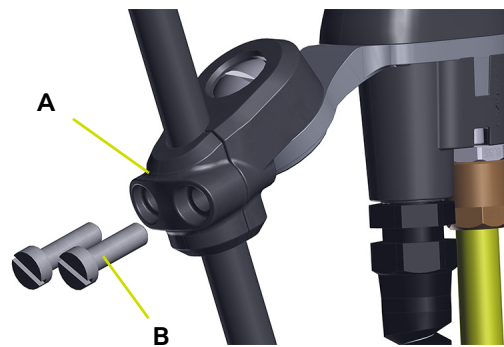

- **Step 2:** Unscrew the two captive screws of the electro-pneumatic coupling, with a 3 Allen wrench.

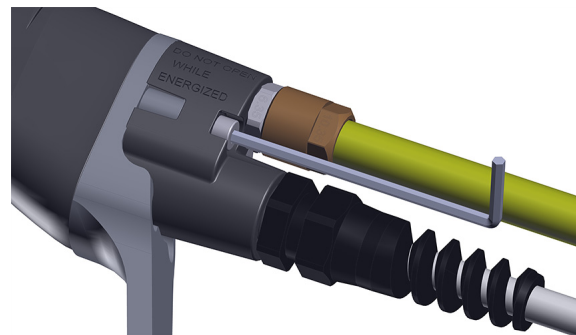

- **Step 3:** Disconnect the electro-pneumatic coupling by pulling on it.

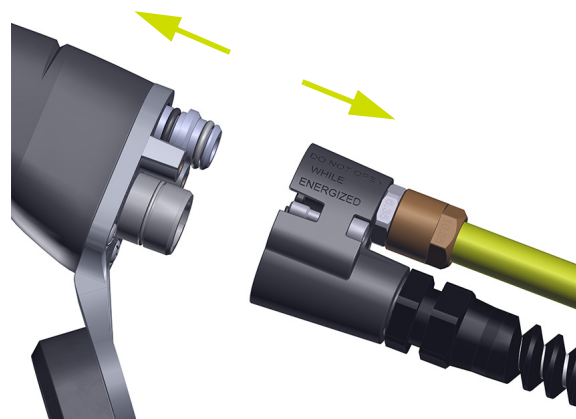

**To reassemble, proceed in reverse order.**

#### 6.4.10. Procedure D3: Replacement of the switch

- **Step 1:** With a 5.5 mm screwdriver, unscrew the shouldered screw. Pull upwards the lever of the switch.
- **Step 2:** Replace the o-ring ([see § 8.1 page 61](#)) Insert the new switch into its housing. Coat with low threadlocker the fastening screw and tighten the screw so that the switch is slightly resistant.



#### 6.4.11. Procedure D4: Replacement of the trigger

- **Step 1:** Using a screwdriver, unscrew both shouldered screws and release both sides of the trigger.

#### Reassembling the trigger:

- Put in place one on the sides of the trigger on its shoulder then slide the other side into its housing.

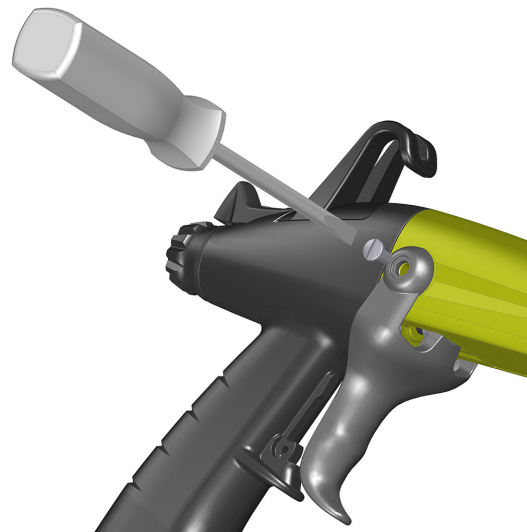

## 6.4.12. Procedure D5: Replacement of the fixing hook

- **Step 1:** Put the switch (A) in position «I».
- **Step 2:** With a 5.5mm screwdriver, unscrew the shouldered screw

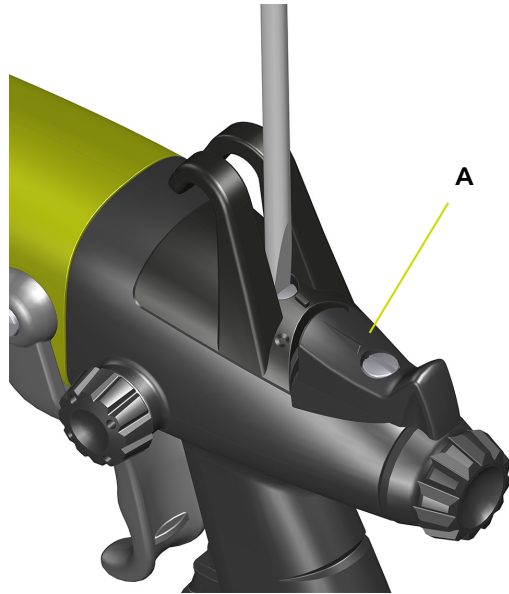

- **Step 3:** Remove the hook by pulling upwards.

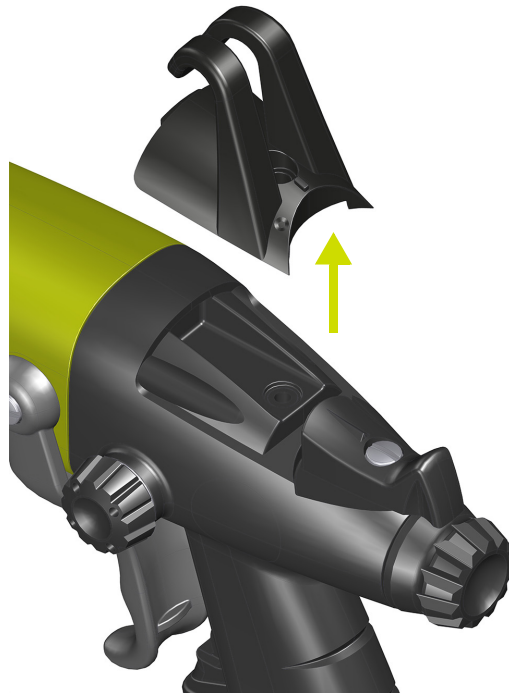

## 7. Troubleshooting Guide

Defaults	Possible Causes	Remedies
Uneven paint flow	Presence of air in the paint circuit	Dump the paint circuit
	Paint flow rate too slow	Increase pressure at the pump or pressurised tank.
	Impurities in the circuit	Verify the filters, then dump the circuit.
	Lack of paint in the paint tank	Refill paint tank
	Paint too viscous	Verify the paint viscosity
The paint is not flowing or only barely flowing upon exiting the gun.	Nozzle clogged	Clean the nozzle
	The nozzle needle does not retract	Verify the nozzle needle line
	Clogged filters	Clean the filters
	No pump pressure	Verify the pump
	Paint too viscous	Verify the paint viscosity
	Obstructed paint hose	Unclog or change the paint hose
The paint is constantly flowing.	Foreign body preventing the nozzle needle from closing.	Disassemble the seat casing, clean it along with the seat. Clean the nozzle needle tip
	Worn nozzle needle	Replace needle and, if necessary, the nozzle/tip holder
	Damaged seat casing	Change the seat casing
The paint exits by the head air holes.	Damaged cartridge	Change the cartridge
	Damaged paint joint	Change the seal
Poor spray	Nozzle partially clogged	Clean the nozzle
	Insufficient paint pressure	Increase the paint flow rate
	Excessive viscosity	Dilute the paint
	Lack of air in the spray	Increase the air pressure
	Excessive paint flow rate	Decrease the paint flow rate
	Nozzle damaged or worn	Change the nozzle
Orange peel effect	Evaporation of solvents too fast	Use heavier solvents
	Paint droplets too large	Increase the spraying distance
		Dilute the paint
		Increase the paint pressure
		Reduce the nozzle size
	Increase the electrostatic effect	

Faults	Possible causes	Remedies
Paint running	Solvents evaporating too slowly	Use lighter solvents
	Spraying applied too slowly	Reduce paint flow
		Increase spraying air pressure
Paint spray overloaded in middle	Paint flow too high	Reduce paint flow
	Nozzle/tip too large	Increase air pressure
	Paint viscosity too great	Use a smaller nozzle/tip
	Air holes partially blocked	Dilute paint
Insufficient electrostatic effect	High voltage power not on	Clean spray head
	High voltage power insufficient	See display on control module
	Distance between spray head and part too great	Increase high voltage power
		Check Nanogun+ Airmix® output voltage
	Part not grounded	Spray from between 200 and 300 mm away
	Excessive ventilation	Clean hooks. Check grounding connection of parts conveyor
	Spraying air pressure too high	Reduce paint booth air extraction rate, ensuring the applicable regulations are still complied with
	Paint flow too high	Reduce spraying air pressure
	Product resistivity too high	Reduce paint flow
	Control module short circuit: - external	Reduce product resistivity to obtain $\rho < 500\text{M}\Omega\cdot\text{cm}$
Control module short circuit: - via needle assembly	Clean outside of the spray gun with a non-conductive solvent ( $\rho > 15\text{M}\Omega\cdot\text{cm}$ )	
Control module short circuit: - via air channels	Use a new, clean and dry case	
Control module short circuit: - via product hose	Replace seal cartridge and needle	
Operator gets electric shocks when touching the part	Clean the air channels of the barrel	Increase the resistivity of paint so that $\rho > 5\text{M}\Omega\cdot\text{cm}$

## 8. Spare Parts

The spare parts are classified in 2 different types:

- **1st emergency parts:**

The 1st emergency parts are strategic components which are not necessarily consumables but which in case of failure prohibit the operation of the equipment.

Depending on the production line's commitment and the production rates imposed, the first emergency parts are not necessarily kept available in the customer's stock.

Indeed, if an interruption of the production flow is possible, storage is not necessary.

On the other hand, if the stop is not possible, the 1st emergency parts will be kept in stock.

- **Wearing parts:**

Wearing parts are consumable components such as O-rings that undergo regular degradation over time during normal operation of the installation. It is therefore advisable to replace them according to a defined frequency and adapted to the operating time of the installation.

The wearing parts must therefore be kept in the customer's stock.



**To guarantee an optimal assembly, spare parts must be stored in a temperature close to their temperature of use. Should the opposite occur, a sufficient waiting time must be observed before the installation, so that all the elements are assembled in the same temperature.**



8.1. Nanogun+ Airmix<sup>®</sup> guns for both high resistivity (HR) solvent-based paints



For the various options: [see § 8.13 page 82.](#)

8.1.1. 120 bar version

Item	Part number	Description	Qty	Unit of sale	Spare Part Level (*)
	910021071-075	Nanogun+ Airmix® 120 bars LR JP with nozzle 09-091 and paint hose 7.5 m	1	1	-
	910021071-150	Nanogun+ Airmix® 120 bars LR JP with nozzle 09-091 and paint hose 15 m	1	1	-
	910021071-300	Nanogun+ Airmix® 120 bars LR JP with nozzle 09-091 and paint hose 30 m	1	1	-
	-	Nanogun+ Airmix® gun ( <a href="#">see § 8.2 page 68</a> )	-	-	-
<b>1</b>	<b>910019358</b>	<b>Air cap ring</b> ( <a href="#">see § 8.1.4 page 67</a> )	<b>1</b>	<b>1</b>	<b>1</b>
<b>1.1</b>	900013829	HP nozzle protection (included in Rep. 1)	1	1	-
<b>3</b>	130001435	Air cap ( <a href="#">see § 8.1.5 page 67</a> )	1	1	-
<b>4</b>	130001420	Nozzle ( <a href="#">see § 8.1.3 page 66</a> )	1	1	1-2
<b>Not shown</b>					
	050123306	Adapter M1/2 JIC - F3/8NPS paint hose	1	1	-

Item	Part number	Description	Qty	Unit of sale	Spare Part Level (*)
	910021070	Nanogun+ Airmix® 120 bar HR JP with nozzle 09-091	1	1	-
	910021070-075	Nanogun+ Airmix® 120 bar HR JP with nozzle 09-091 and paint hose 7.5 m	1	1	-
	910021070-150	Nanogun+ Airmix® 120 bar HR JP with nozzle 09-091 and paint hose 15 m	1	1	-
	-	Nanogun+ Airmix® gun ( <a href="#">see § 8.2 page 68</a> )	-	-	-
<b>1</b>	<b>910019358</b>	<b>Air cap ring</b> ( <a href="#">see § 8.1.4 page 67</a> )	<b>1</b>	<b>1</b>	<b>1</b>
<b>1.1</b>	900013829	HP nozzle protection (included in Rep. 1)	1	1	-
<b>3</b>	130001435	Air cap ( <a href="#">see § 8.1.5 page 67</a> )	1	1	-
<b>4</b>	130001420	Nozzle ( <a href="#">see § 8.1.3 page 66</a> )	1	1	1-2
<b>Not shown</b>					
	050123306	Adapter M1/2 JIC - F3/8NPS paint hose	1	1	-

Item	Part number	Description	Qty	Unit of sale	Spare Part Level (*)
	910025956-075	Nanogun+ Airmix <sup>®</sup> 120 bar HR JP with nozzle 09-091and paint hose 7.5 m	1	1	-
	910025956-150	Nanogun+ Airmix <sup>®</sup> 120 bar HR JP with nozzle 09-091and paint hose 15 m	1	1	-
	910025956-300	Nanogun+ Airmix <sup>®</sup> 120 bar HR JP with nozzle 09-091and paint hose 30 m	1	1	-
	-	Nanogun+ Airmix <sup>®</sup> gun ( <a href="#">see § 8.2 page 68</a> )	-	-	-
<b>1</b>	<b>910019358</b>	<b>Air cap ring (<a href="#">see § 8.1.4 page 67</a>)</b>	<b>1</b>	<b>1</b>	<b>1</b>
<b>1.1</b>	900013829	HP nozzle protection (included in Rep. 1)	1	1	-
<b>3</b>	130001435	Air cap ( <a href="#">see § 8.1.5 page 67</a> )	1	1	-
<b>4</b>	130001420	Nozzle ( <a href="#">see § 8.1.3 page 66</a> )	1	1	1-2
<b>Not shown</b>					
	050123306	Adapter M1/2 JIC - F3/8NPS paint hose	1	1	-

(\*)

**Level 1: 1st emergency parts**

**Level 2: Wearing parts**

8.1.2. 200 bar version

Item	Part number	Description	Qty	Unit of sale	Spare Part Level (*)
	910021077-075	Nanogun+ Airmix <sup>®</sup> 200 bars LR JP with nozzle 09-091 and paint hose 7.5 m	1	1	-
	910021077-150	Nanogun+ Airmix <sup>®</sup> 200 bars LR JP with nozzle 09-091 and paint hose 15 m	1	1	-
	910021077-300	Nanogun+ Airmix <sup>®</sup> 200 bars LR JP with nozzle 09-091 and paint hose 30 m	1	1	-
	-	Nanogun+ Airmix <sup>®</sup> gun (see § 8.2 page 68)	-	-	-
<b>1</b>	<b>910019358</b>	<b>Air cap ring (see § 8.1.4 page 67)</b>	<b>1</b>	<b>1</b>	<b>1</b>
<b>1.1</b>	900013829	HP nozzle protection (included in Rep. 1)	1	1	-
<b>3</b>	130001435	Air cap (see § 8.1.5 page 67)	1	1	-
<b>4</b>	130001420	Nozzle (see § 8.1.3 page 66)	1	1	1-2
<b>Not shown</b>					
	050123306	Adapter M1/2 JIC - F3/8NPS paint hose	1	1	-

Item	Part number	Description	Qty	Unit of sale	Spare Part Level (*)
	910021076	Nanogun+ Airmix <sup>®</sup> 200 bars HR JP with nozzle 09-091	1	1	-
	910021076-075	Nanogun+ Airmix <sup>®</sup> 200 bars HR JP with nozzle 09-091 and paint hose 7.5 m	1	1	-
	910021076-150	Nanogun+ Airmix <sup>®</sup> 200 bars HR JP with nozzle 09-091 and paint hose 15 m	1	1	-
	-	Nanogun+ Airmix <sup>®</sup> gun (see § 8.2 page 68)	-	-	-
<b>1</b>	<b>910019358</b>	<b>Air cap ring (see § 8.1.4 page 67)</b>	<b>1</b>	<b>1</b>	<b>1</b>
<b>1.1</b>	900013829	HP nozzle protection (included in Rep. 1)	1	1	-
<b>3</b>	130001435	Air cap (see § 8.1.5 page 67)	1	1	-
<b>4</b>	130001420	Nozzle (see § 8.1.3 page 66)	1	1	1-2
<b>Not shown</b>					
	050123306	Adapter M1/2 JIC - F3/8NPS paint hose	1	1	-

Item	Part number	Description	Qty	Unit of sale	Spare Part Level (*)
	910025957-075	Nanogun+ Airmix <sup>®</sup> 200 bars HR JP with nozzle 09-091and paint hose 7.5 m	1	1	-
	910025957-150	Nanogun+ Airmix <sup>®</sup> 200 bars HR JP with nozzle 09-091and paint hose 15 m	1	1	-
	910025957-300	Nanogun+ Airmix <sup>®</sup> 200 bars HR JP with nozzle 09-091and paint hose 30 m	1	1	-
	-	Nanogun+ Airmix <sup>®</sup> gun ( <a href="#">see § 8.2 page 68</a> )	-	-	-
<b>1</b>	<b>910019358</b>	<b>Air cap ring</b> ( <a href="#">see § 8.1.4 page 67</a> )	<b>1</b>	<b>1</b>	<b>1</b>
<b>1.1</b>	900013829	HP nozzle protection (included in Rep. 1)	1	1	-
<b>3</b>	130001435	Air cap ( <a href="#">see § 8.1.5 page 67</a> )	1	1	-
<b>4</b>	130001420	Nozzle ( <a href="#">see § 8.1.3 page 66</a> )	1	1	1-2
<b>Not shown</b>					
	050123306	Adapter M1/2 JIC - F3/8NPS paint hose	1	1	-

(\*)

Level 1: 1st emergency parts

Level 2: Wearing parts

### 8.1.3. The nozzles as an option

Nozzles equipped with sieve no.4:

Part Number	Description	Quantity
130001597	Nozzle MX03.05	Option
130001563	Nozzle MX03.07	Option
130001564	Nozzle MX04.05	Option
130001565	Nozzle MX04.07	Option
130001566	Nozzle MX04.09	Option
130001414	Nozzle MX04.111	Option
130001415	Nozzle MX04.131	Option
130001416	Nozzle MX06.091	Option
130001417	Nozzle MX06.111	Option
130001418	Nozzle MX06.131	Option
130001419	Nozzle MX06.151	Option
129609901	Sieve no. 4	10

Nozzles equipped with seal:

Part Number	Description	Quantity
130001420	Nozzle MX09.091	1
130001421	Nozzle MX09.111	Option
130001422	Nozzle MX09.131	Option
130001423	Nozzle MX09.151	Option
130001424	Nozzle MX12.091	Option
130001425	Nozzle MX12.111	Option
130001426	Nozzle MX12.131	Option
130001427	Nozzle MX12.151	Option
130001428	Nozzle MX14.091	Option
130001429	Nozzle MX14.111	Option
130001430	Nozzle MX14.131	Option
130001431	Nozzle MX14.151	Option
130001432	Nozzle MX14.171	Option
130001433	Nozzle MX18.111	Option
129529903	Seal	10

Hollow cone nozzles:

Part Number	Description	Quantity
910025472	Injector 20 hollow cone nozzle	Option
910025473	Injector 30 hollow cone nozzle	Option
910025474	Injector 40 hollow cone nozzle	Option
910025475	Injector 50 hollow cone nozzle	Option
910025476	Injector 60 hollow cone nozzle	Option
910025477	Injector 70 hollow cone nozzle	Option

### 8.1.4. Fitted air cap ring

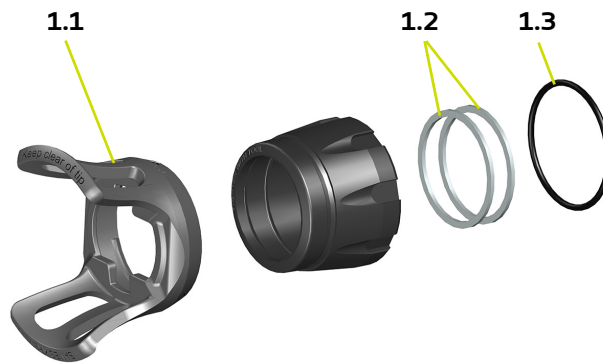

Item	Part number	Description	Qty	Unit of sale	Spare Part Level (*)
<b>1</b>	<b>910019358</b>	<b>Fitted air cap ring</b>	<b>1</b>	<b>1</b>	<b>1</b>
<b>1.1</b>	900013829	HP nozzle protection	1	1	1-2
<b>1.2</b>	900010164	PTFE flat seal	2	1	1-2
<b>1.3</b>	160000170	FEP/FKM seal	1	1	2

(\*)

Level 1: 1st emergency parts

Level 2: Wearing parts

### 8.1.5. Equipped Air cap

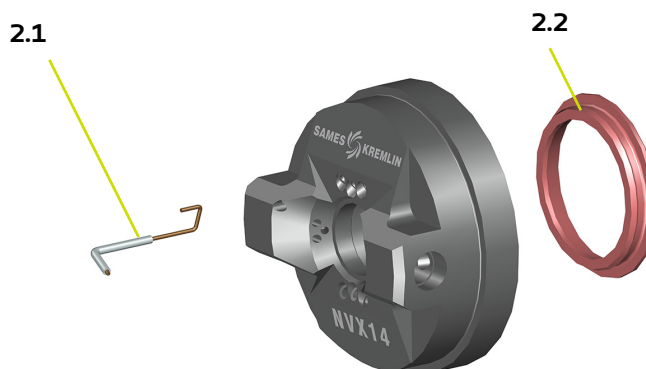

Item	Part number	Description	Qty	Unit of sale	Spare Part Level (*)
<b>2</b>	<b>130001435</b>	<b>Equipped air cap</b>	<b>1</b>	<b>1</b>	<b>1</b>
<b>2.1</b>	132284012	Electrode and PTFE tube	1	5	1-2
<b>2.2</b>	132284010	PTFE conductive washer	1	1	1-2

(\*)

Level 1: 1st emergency parts

Level 2: Wearing parts

## 8.2. Nanogun+ Airmix® spray guns

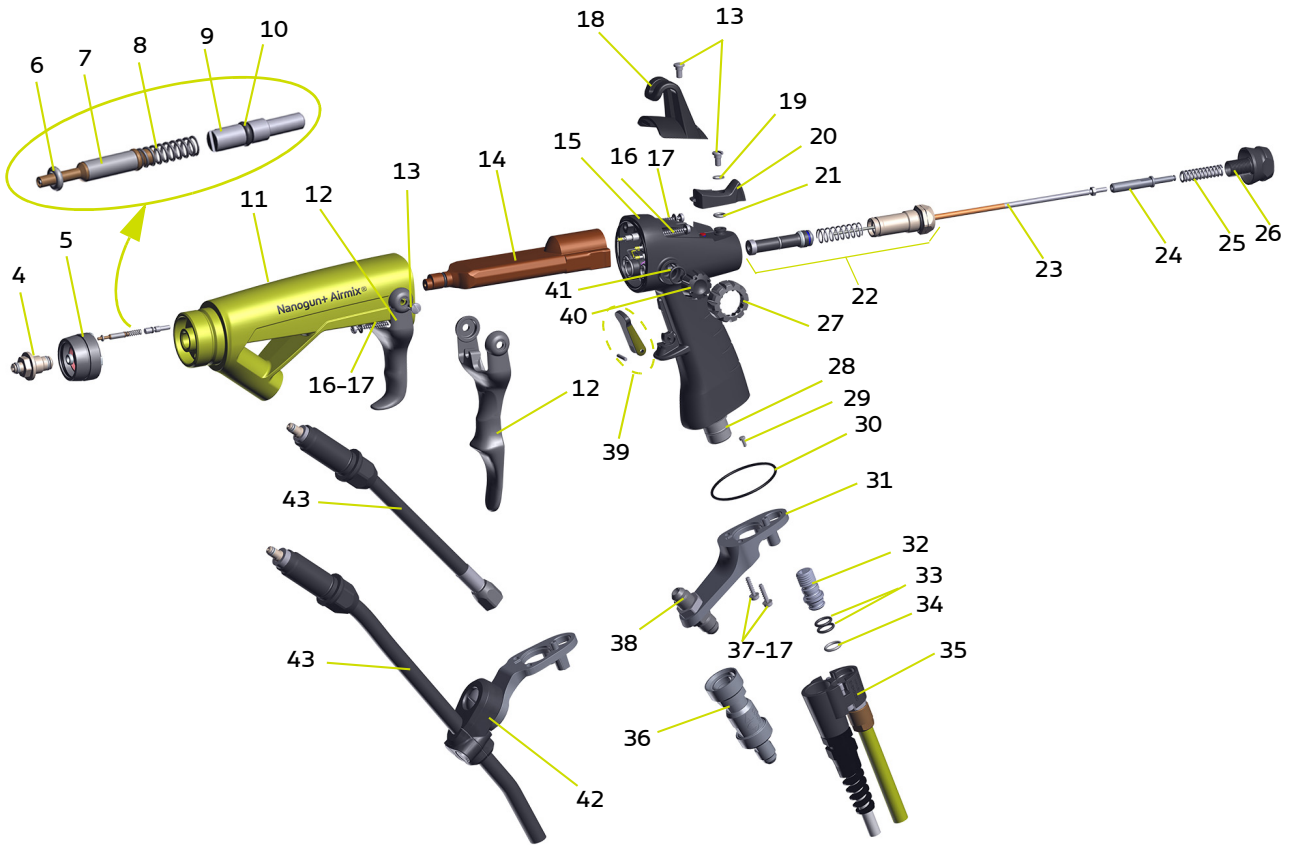



Item	Part number	Description	Qty	Unit of sale	Spare Part Level (*)
	-	<b>Nanogun+ Airmix<sup>®</sup> gun</b>	-	-	-
4	910019359	<b>Fitted seat casing</b> ( <a href="#">see § 8.3 page 71</a> )	1	1	1-2
5	910019360	<b>Nanogun+ Airmix<sup>®</sup> fitted adapter</b> ( <a href="#">see § 8.4 page 71</a> )	1	1	-
6	J3STKL014	Chemically inert O-ring (included in item 7)	1	1	2
7	910015934	Fitted high-voltage contact (included in item 11)	1	1	1-2
8	900014787	Spring (included in item 8)	1	1	2
9	910019356	<b>High-voltage contact screw</b> (included in item 11)	1	1	2
10	J2FTDF014	O-ring (included in item 9)	1	1	1-2
11	910019514	<b>Equipped barrel</b> ( <a href="#">see § 8.5 page 72</a> )	1	1	-
12	900010237	Trigger	1	1	-
	900014446	4-finger trigger	option	1	-
13	900010385	C M4 curved washer head screw	4	1	1
14	910015508	<b>Equipped high-voltage cascade</b>	1	1	1
	J2FTDF082	O-ring	1	1	-
15	910022672	<b>Fitted Nanogun+ Airmix<sup>®</sup> handle 120 bar</b>	1	1	-
	910022679	<b>Fitted Nanogun+ Airmix<sup>®</sup> handle 200 bar</b>	1	1	-
16	250000036	Handle / barrel fastening screw	4	1	-
17	J4BRND039	Fibre seal for fastening screw	6	1	-
18	900010239	Fastening hook	1	1	-
19	900013808	PTFE flat washer (included in item 18)	1	1	-
20	910018204	<b>On/off handle with o-ring and magnet</b> (included in item 15)	1	1	-
21	J3STKL005	Chemically inert O-ring (included in item 20)	1	1	-
22	-	<b>Air valve and air valve nut</b> ( <a href="#">see § 8.6 page 73</a> )	1	-	-
23	910019508	<b>Fitted needle</b> ( <a href="#">see § 8.7 page 74</a> )	1	1	1-2
24	900010882	High-pressure paint stop	1	1	-
25	900010266	Paint spring 120 bar	1	1	-
	900010267	Paint spring 200 bar	1	1	-
26	900015784	Knurl back of paint	1	1	-
27	900020056	Adapter additional air settings button	option	1	-
28	160000041	White chemically inert seal (included in item 15)	1	1	2
29	X3GJCP004	Zinc coated PT K25x6 screw	1	1	-
30	160000067	Red FKM seal (included in item 15)	1	1	2
31	900021346	HR gun base	1	1	-
	900010009	LR gun base	1	1	-
32	910006118	<b>Fitted air nipple</b>	1	1	-
33	J2FTCF018	Black FKM O-ring (included in item 32)	2	1	2

34	J3STKL018	White chemically inert O-ring (included in item 32)	1	1	2
35	910015869-XXX	<b>Electro-pneumatic coupling</b> ( <a href="#">see § 8.8 page 74</a> )	1	1	-
36	129670405	Rotating air coupling	option	1	2
37	250000037	Base-handle fastening screw	2	1	-
38	900021299	Connecting nut for LR product hose	1	1	-
39	910022663	<b>Trigger / pin lock assembly</b>	1	1	-
40	910014166	Fitted additional air settings button (included in item12)	1	1	-
41	J2FTDF121	Black FKM O-ring (included in item 40)	1	1	2
42	910031353	<b>Hose holder LR equipped</b>	1	1	-
43	-	<b>Paint hose</b> ( <a href="#">see § 8.9 page 75</a> )	1	1	2

(\*)

Level 1: 1st emergency parts

Level 2: Wearing parts



It is strictly forbidden to disassemble the knurl back of paint (Item 26) when the spray gun is under pressure.

### 8.3. Equipped seat casing (Flat spray only)

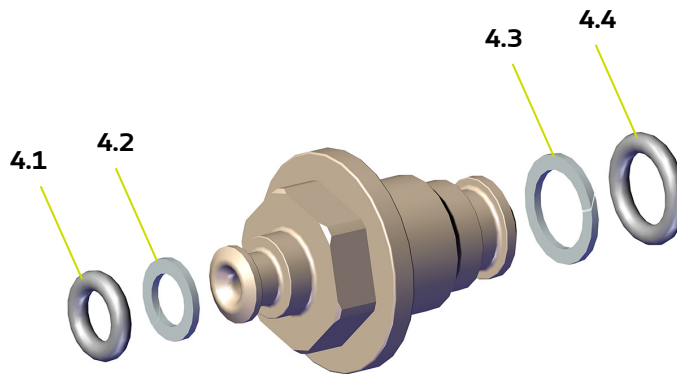

Item	Part number	Description	Qty	Unit of sale	Spare Part Level (*)
<b>4</b>	<b>910019359</b>	<b>Equipped seat casing</b>	<b>1</b>	<b>1</b>	<b>1</b>
<b>4.1</b>	J3STKL046	O-ring - chemically inert	1	1	1-2
<b>4.2</b>	900013368	Anti-extrusion ring	1	1	1-2
<b>4.3</b>	900012300	Anti-extrusion ring	1	1	1-2
<b>4.4</b>	J3STKL075	O-ring - chemically inert	1	1	1-2

### 8.4. Equipped adapter (Flat spray only)

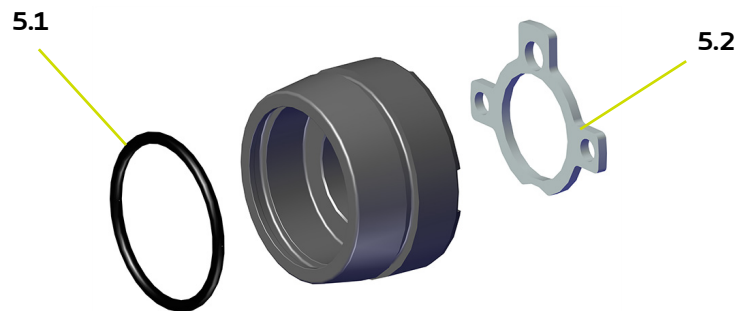

Item	Part number	Description	Qty	Unit of sale	Spare Part Level (*)
<b>5</b>	<b>910019360</b>	<b>Equipped adapter</b>	<b>1</b>	<b>1</b>	<b>1</b>
<b>5.1</b>	J2FENV288	O-ring - FEP FKM	1	1	1-2
<b>5.2</b>	900014821	Flat seal	1	1	1-2

(\*)

Level 1: 1st emergency parts

Level 2: Wearing parts

### 8.5. Barrel assembly

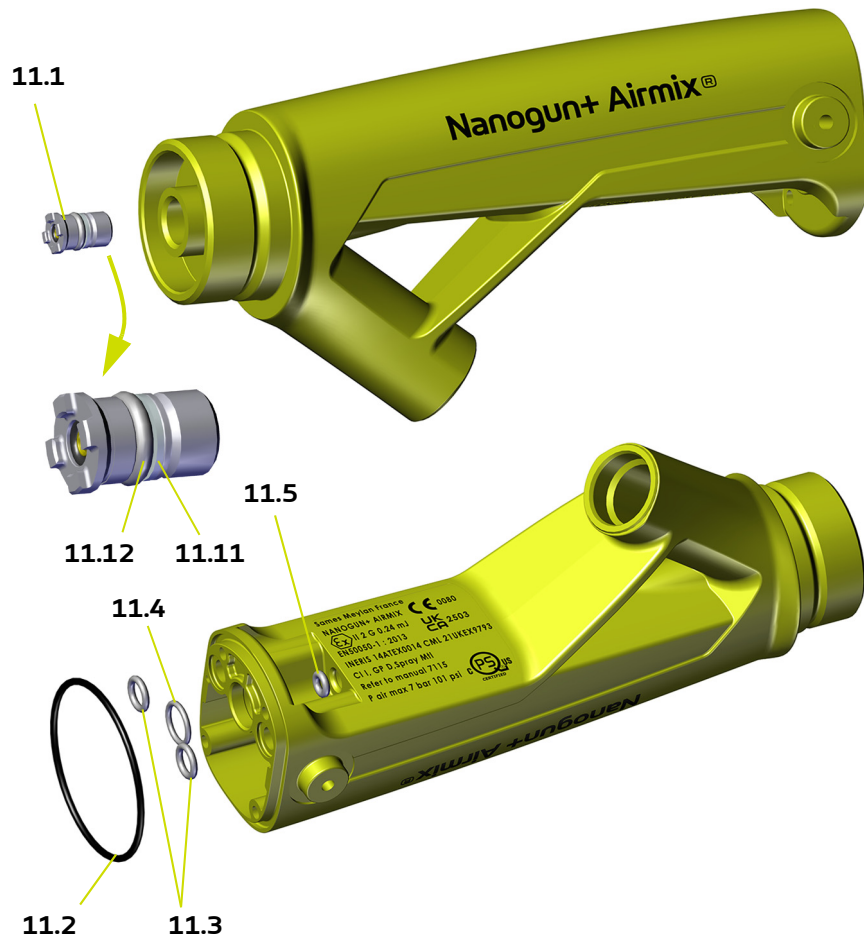

Item	Part number	Description	Qty	Unit of sale	Spare Part Level (*)
<b>11</b>	<b>910019514</b>	<b>Equipped barrel</b>	<b>1</b>	<b>1</b>	<b>-</b>
<b>11.1</b>	<b>910015881</b>	<b>Seal cartridge</b>	<b>1</b>	<b>1</b>	<b>1-2</b>
<b>11.11</b>	900012782	Anti-extrusion ring (included in Rep. 11.1)	1	1	2
<b>11.12</b>	J3STKL005	O-ring - chemically inert (included in Rep. 11.1)	1	1	2
<b>11.2</b>	J2FENV435	O-ring - FEP Viton	1	1	2
<b>11.3</b>	J3STKL078	O-ring - chemically inert	2	1	2
<b>11.4</b>	J3STKL019	O-ring - chemically inert	1	1	2
<b>11.5</b>	J3STKL032	O-ring - chemically inert	1	1	2

(\*)

Level 1: 1st emergency parts

Level 2: Wearing parts

## 8.6. Air valve and Nut air valve

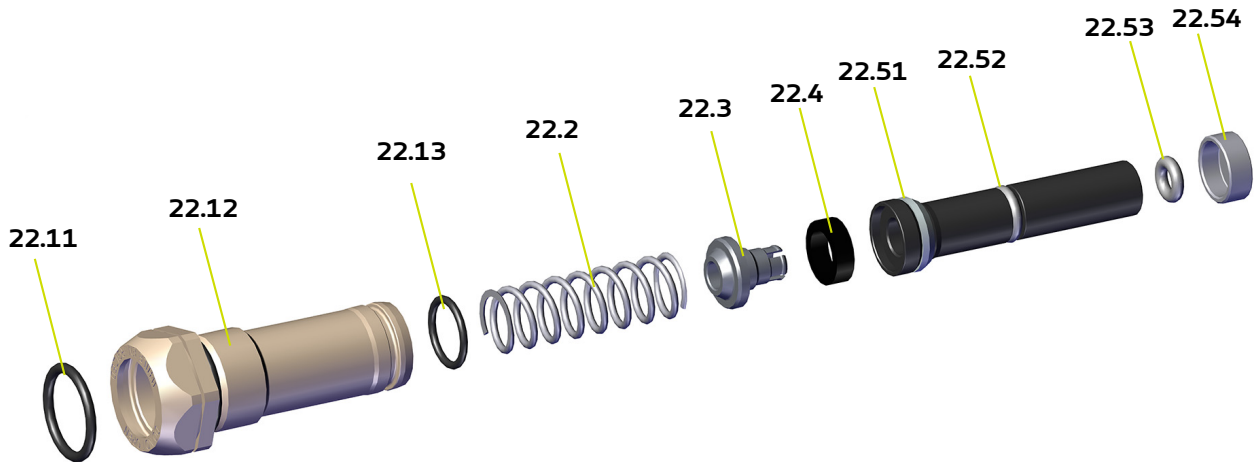

Item	Part number	Description	Qty	Unit of sale	Spare Part Level (*)
<b>22</b>	-	<b>Air valve and air valve nut assembly</b>	<b>1</b>	-	-
<b>22.1</b>	<b>910015922</b>	<b>Air valve nut assembly</b>	<b>1</b>	<b>1</b>	-
<b>22.11</b>	J2FTDF155	O-ring, FKM black	1	1	1
<b>22.12</b>	J2FTDF160	O-ring, FKM black	1	1	1-2
<b>22.13</b>	J2FTDF999	O-ring, FKM black	1	1	1-2
<b>22.3</b>	-	Magnet stop	1	-	-
<b>22.4</b>	-	Magnet	1	-	-
<b>22.2</b>	900009024	Air spring	1	1	-
<b>22.5</b>	<b>910018203</b>	<b>Air valve</b>	<b>1</b>	<b>1</b>	<b>1</b>
<b>22.51</b>	900010256	Sealing ring	1	1	2
<b>22.52</b>	J3STKL005	O-ring, chemically inert (outer of valve)	1	1	2
<b>22.53</b>	J3STKL032	O-ring, chemically inert (inner of valve)	1	1	2
<b>22.54</b>	900020022	Valve support washer	1	1	2

(\*)

**Level 1: 1st emergency parts**

**Level 2: Wearing parts**



**Recover the magnet (Item 19.4) by memorising the mounting direction on the old air valve in order to keep the same trigger values.**

**If the magnet is lost, contact Sames ([see § 6.4.6.1 page 51](#)).**

### 8.7. Needle assembly

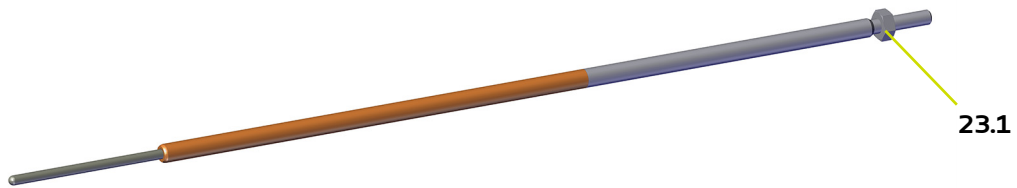

Item	Part number	Description	Qty	Unit of sale	Spare Part Level (*)
23	910019508	Equipped needle	1	1	1-2
23.1	X7CEHU003	H M3 U brass nut	1	1	-

(\*)

Level 1: 1st emergency parts

Level 2: Wearing parts

### 8.8. Electropneumatic coupling sets

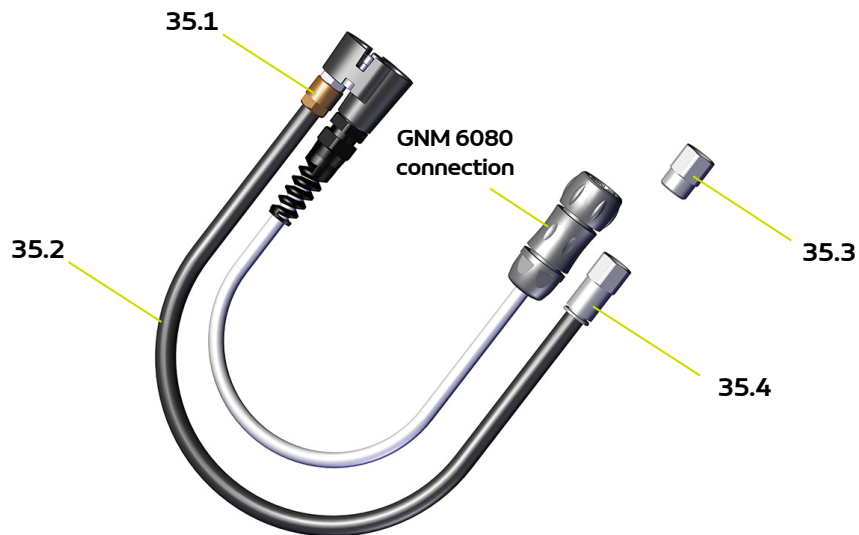

Item	Part number	Description	Qty	Unit of sale	Spare Part Level (*)
35	910015869-100	10-m electro-pneumatic coupling	1	1	-
	910015869-200	20-m electro-pneumatic coupling	1	1	-
	910015869-300	30-m electro-pneumatic coupling	1	1	-
35.1	900015289	Simple male union	1	1	-
35.2	910021087-100	Equipped air hose outer diameter: 10	10 m	1	2
	910021087-200		20 m		
	910021087-300		30 m		
35.3	F6RLHG362	NPT female / BSP male adapter	option	1	-
35.4	130000527	Quick coupling	1	1	-

## 8.9. Paint hoses

### 8.9.1. Pour pistolets Nanogun+ Airmix® HR



Item	Part number	Description	Qty	Unit of sale	Spare Part Level (*)
43	<b>Pour pistolets Nanogun+ Airmix® HR</b>				
43.1	910019204-075	Black 7.5-m HR product hose Ø 5	1	1	2
	910019204-150	Black 15-m HR product hose Ø 5	1	1	2
	910019204-300	Black 30-m HR product hose Ø 5	1	1	2
43.11	050450605	Product hose, lg.: 7.5 m (included in item 43.1)	1	1	2
	050450607	Product hose, lg.: 15 m (included in item 43.1)	1	1	2
	050450609	Product hose, lg.: 30 m (included in item 43.1)	1	1	2
43.12	050102301	Steel fitting MM 1/2" JIC (included in item 43.1)	1	1	2
43.13	050451155	Whip Nanogun+ Airmix® (included in item 43.1)	1	1	2
43.2	910020147	<b>Equipped product hose Ø 4</b>	1	1	2
43.21	J3STKL028	Chemically inert O-ring (included in item 43.2)	1	1	2
43.22	900013398	Anti-extrusion ring (included in item 43.2)	1	1	-
43.23	J2FTDF177	Black FKM O-ring (included in item 43.2)	1	1	2

(\*)

**Level 1: 1st emergency parts**

**Level 2: Wearing parts**

**Remarks:**

- For large flow / high viscosity assembly: the product hose (Item 43.11) will be connected directly to the handle, the whip and the steel fitting will not be used.  
The filter and / or the rotating coupling ([see § 8.13 page 82](#)) may be placed between the fitting under the butt and the product hose.
- **For the standard assembly:** The whip will be connected to the butt of the gun and will be connected to the product supply hose via the steel fitting (Item 43.12).  
The filter and / or the rotating coupling ([see § 8.13 page 82](#)) may be placed between the fitting under the butt and the product hose.  
The filter ([see § 8.13 page 82](#)) may be placed between the steel fitting and the product hose.

8.9.2. For Nanogun+ Airmix® LR guns



Item	Part number	Description	Qty	Unit of sale	Spare Part Level (*)
<b>43</b>	<b>For Nanogun+ Airmix® LR guns</b>				
	910020165-075	PTFE 7.5-m LR product hose Ø 5	1	1	2
<b>43.3</b>	910020165-150	PTFE 15-m LR product hose Ø 5	1	1	2
	910020165-300	PTFE 30-m LR product hose Ø 5	1	1	2
<b>43.31</b>	J3STKL028	Chemically inert O-ring (included in item 1)	1	1	2
<b>43.32</b>	900013398	Anti-extrusion ring (included in item1)	1	1	-
<b>43.33</b>	J2FTDF177	Black FKM O-ring (included in item 1)	1	1	2
<b>43.4</b>	E3RPLS018	Cable gland nut	1	1	-

(\*)

Level 1: 1st emergency parts

Level 2: Wearing parts



8.9.3. For Nanogun+ Airmix® MR guns

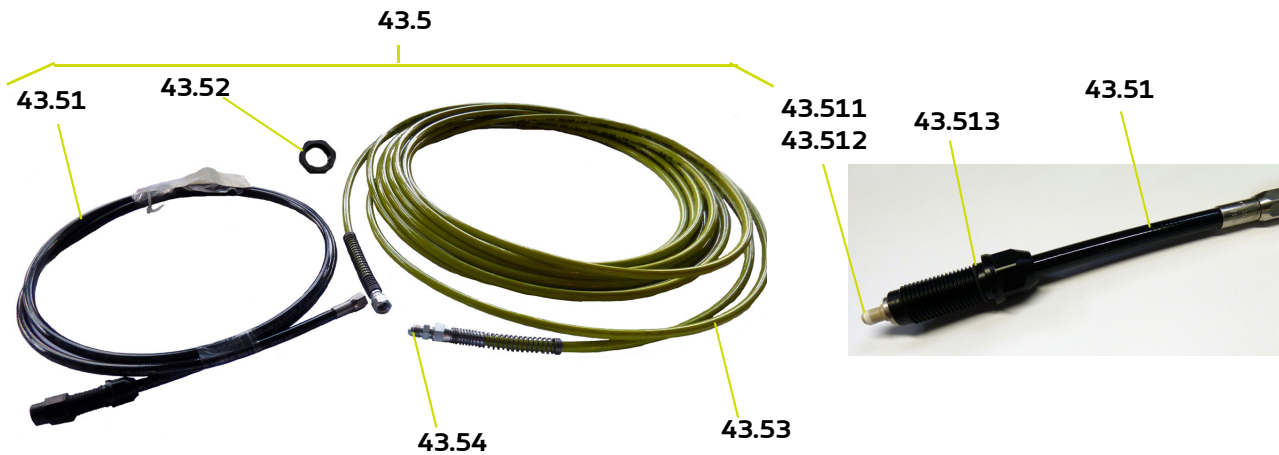

Item	Part number	Description	Qty	Unit of sale	Spare Part Level (*)
43	<b>For Nanogun+ Airmix® MR guns</b>				
43.5	910025953-075	Product hose MR 7.5 m Ø 5	1	1	2
	910025953-150	Product hose MR 15 m Ø 5	1	1	2
	910025953-300	Product hose MR 30 m Ø 5	1	1	2
43.51	910025541	Whip HP Ø 4 (included in item 43.5)	1	1	2
43.511	J3STKL028	Chemically inert O-ring (included in item 43.51)	1	1	2
43.512	900013398	Anti-extrusion ring (included in item 43.51)	1	1	-
43.513	J2FTDF177	Black FKM O-ring (included in item 43.51)	1	1	2
43.52	E3RPLS018	Cable gland nut	1	1	-
43.53	050450605	Product hose lg: 7.5 m (included in item 43.5)	1	1	2
	050450607	Product hose lg: 15 m (included in item 43.5)	1	1	2
	050450609	Product hose lg: 30m (included in item 43.5)	1	1	2
43.54	050102301	Steel fitting MM 1/2" JIC (included in item 43.5)	1	1	-

(\*)

Level 1: 1st emergency parts

Level 2: Wearing parts

**Remarque:**

- The whip will be connected to the butt of the gun and to the base via the cable gland nut and will be connected to the product supply hose via the steel fitting (item 43.54).  
The filter and / or the rotating coupling ([see § 8.13 page 82](#)) may be placed between the fitting and the product supply hose.

## 8.10. Nanogun+ Airspray seal set

Part number	Description	Location	Quantity
<b>910022694</b>	<b>Nanogun+ Airmix<sup>®</sup> seal kit</b>		<b>1</b>
J3STKL005	Chemically inert O-ring	Barrel, air valve, on/off button	3
J2FENV435	FEP/FKM O-ring	Barrel	1
J3STKL078	Chemically inert O-ring	Barrel	2
J3STKL019	Chemically inert O-ring	Barrel	1
910015881	Seal cartridge	Barrel	1
J3STKL032	Chemically inert O-ring	Barrel, air valve	2
900012782	Anti-extrusion ring	Barrel	1
160000041	Chemically inert O-ring	Handle	1
160000067	Red FKM O-ring	Handle	1
J2FTCF018	Black FKM O-ring	Air nipple	2
J3STKL018	Chemically inert O-ring	Air nipple	1
J4BRND039	Fiber seal	Handle-barrel fastening, base-handle fastening	6
900010256	Sealing ring	Air valve	1
J3STKL075	Chemically inert O-ring	Equipped seat casing	1
900012300	Anti-extrusion ring	Equipped seat casing	1
J3STKL046	Chemically inert O-ring	Equipped seat casing	1
900013368	Anti-extrusion ring	Equipped seat casing	1
900014821	Adapter flat joint	Equipped adapter	1
J2FENV288	FEP/FKM O-ring	Equipped adapter	1
J3STKL014	Chemically inert O-ring	High-voltage contact	1

### 8.11. Hollow cone kit

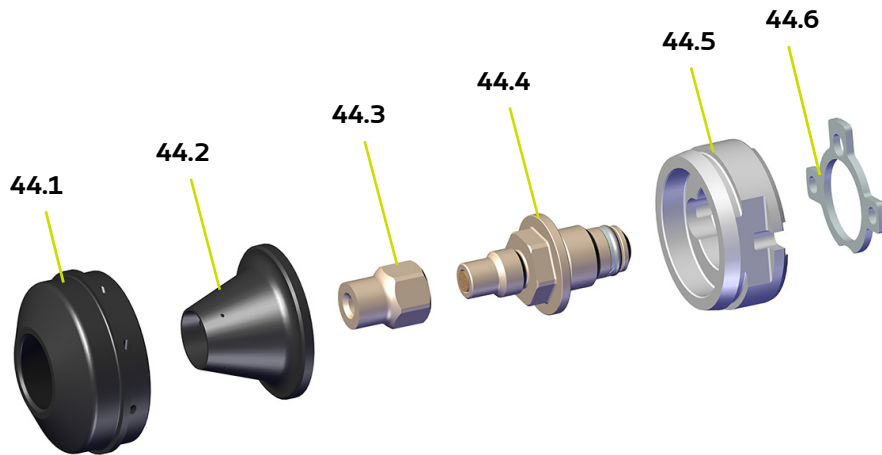

Item	Part number	Description	Qty	Unit of sale	Spare Part Level (*)
44	910025480-20	Hollow cone kit K20	1	1	2
	910025480-30	Hollow cone kit K30	1	1	2
	910025480-40	Hollow cone kit K40	1	1	2
	910025480-50	Hollow cone kit K50	1	1	2
	910025480-60	Hollow cone kit K60	1	1	2
	910025480-70	Hollow cone kit K70	1	1	2
44.11	900011505	Cap	1	1	2
44.22	910018917	Spraying cone	1	1	2
44.3	910025472	Injector 20 hollow cone	1	1	1-2
	910025473	Injector 30 hollow cone	1	1	1-2
	910025474	Injector 40 hollow cone	1	1	1-2
	910025475	Injector 50 hollow cone	1	1	1-2
	910025476	Injector 60 hollow cone	1	1	1-2
	910025477	Injector 70 hollow cone	1	1	1-2
44.4	910025478	Equipped hollow cone seat casing <a href="#">(see § 8.11.1 page 80)</a>	1	1	2
44.5	900011504	Hollow cone adaptor	1	1	-
44.6	900014821	Flat seal	1	1	2

(\*)

Level 1: 1st emergency parts

Level 2: Wearing parts

8.11.1. Equipped hollow cone seat casing

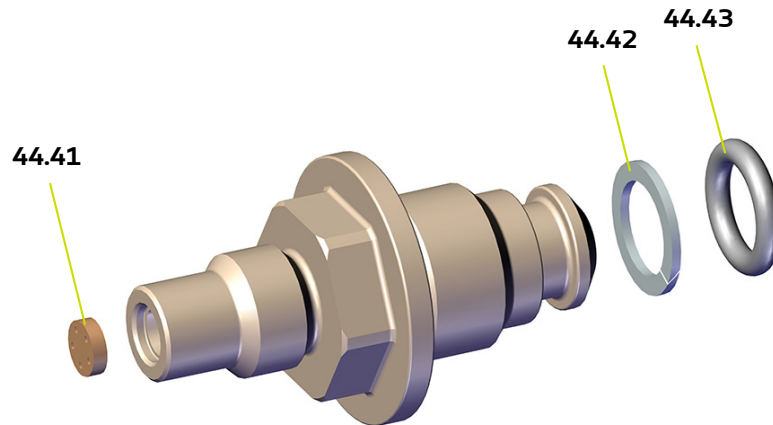

Item	Part number	Description	Qty	Unit of sale	Spare Part Level (*)
<b>44.4</b>	<b>910025478</b>	<b>Equipped hollow cone seat casing</b>	<b>1</b>	<b>1</b>	<b>2</b>
<b>44.41</b>	999469300	Distribution carbine pad	1	1	1
<b>44.42</b>	900012300	Anti-extrusion ring	1	1	1
<b>44.43</b>	J3STKL075	Chemically inert O-ring	1	1	1

(\*)

Level 1: 1st emergency parts

Level 2: Wearing parts

### 8.11.2. Procedure for changing from a flat spray to a round spray



To carry out this operation, the gun must be disconnected from any supply (product / air / current).

#### Remove the flat spray:

- Loosen the cap nut (P/N: 910019358).
- Remove the cap (P/N: 130001435), if the injector does not come away at the same time, remove it too.
- Loosen the seat casing (P/N 910019359) while pressing the trigger.
- Remove the adaptor (P/N: 910019360) and the flat seal (P/N.: 900014821) located at the rear. Make sure you do not lose or break the high voltage contact and the O-ring (P/N.: J3STKL014).
- Extract the first split ring (P/N: 900010164) inside the cap nut and remove the cap.

#### Install the round spray (hollow cone):

- Put the flat seal in place (P/N: 900014821) and the hollow cone adaptor (P/N: 900011504), Make sure you do not lose or break the high voltage contact and the O-ring (P/N.: J3STKL014)
- Add a little dielectric grease to the HV contact and a film to the seat casing thread. Make sure you do not lose the distribution pad carbide (P/N: 999469300) at the front of the part
- Screw the seat casing fully onto the barrel while pressing the trigger.
- Add a film of dielectric grease to the threading at the front of the seat casing; make sure you do not get any on the distribution carbide pad.
- Screw the injector fully on the seat casing.
- Insert the cap into the cap nut and put the retaining ring back in place.
- Put the cone in place.
- Add a film of grease on the barrel threading.
- Add a film of grease on the barrel threading.

### 8.12. GNM 6080 Control module



Part number	Description	Qty	Unit of sale	Spare Part Level
910017193	CE GNM 6080 control module	1	1	-
910017192	GNM 6080 control module (USA-CANADA only)	1	1	-
910005759	GNM 6080 attachment kit	1	1	-
842635	5-m ground cable, lug dia.: 6	1	1	-

(\*)

Level 1: 1st emergency parts

Level 2: Wearing parts

### 8.13. Options for Nanogun+ Airmix<sup>®</sup> guns

#### Online product filter

Designation	Part Number	Versions
Filter (M / F 1/2 JIC)	130000322	HR / LR* 120 or 200 bar
Sieve 6	129609908	HR/LR 120 or 200 bar

\* Reduced filter dimension installed under the gun handle for the HR versions or at the pump outlet for the LR versions (in which case, the pump must be equipped with a M 1/2 JIC output coupling)

#### Rotating coupling

Designation	Part Number	Versions
High-pressure product rotating coupling (M / F 1/2 JIC)	129670405	HR (versions 120 and 200 bar)

## 8.14. Various

### 8.14.1. Protective hose covering

This covering can be used to protect hoses and cables to ensure long life and flexibility.

Description	Part number	Unit of sale
 <p>Rilsan Protective hose covering with 30 collars</p>	910021086	50 m roll

### 8.14.2. Protective case for spray gun

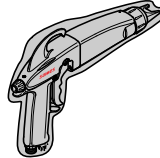
Description	Part number	Unit of sale
 <p>Protective case</p>	900011711	10

### 8.14.3. Warning notice

Description	Part number	Unit of sale
 <p>Warning notice</p>	1407684	1

### 8.14.4. Safety valve

Description	Part number	Unit of sale
 <p>Safety valve 6.5 bar 1/4 G</p>	903080401	1

## 9. The different versions

### 9.1. Equipments

<b>Titre</b>	<b>Pistolet NANOGUN MX "Haute Pression" HP</b>		
<b>Title</b>	<i>NANOGUN MX gun type High Pressure" HP</i>		
	Pistolet NANOGUN MX CE+UK+C/US		
<b>N° GUN</b>	<b>Pistolet NANOGUN MX HP Haute résistivité HR</b>		
	<i>NANOGUN MX gun type HP High Resistivity LR</i>		
	CE+UK+C/US		
910021070	Haute résistivité 120 bars		
910021070-075	Haute résistivité 120 bars		
910021070-150	Haute résistivité 120 bars		
910021070-300	Haute résistivité 120 bars		
910021076	Haute résistivité 200 bars		
910021076-075	Haute résistivité 200 bars		
910021076-150	Haute résistivité 200 bars		
910021076-300	Haute résistivité 200 bars		
<b>N° GUN</b>	<b>Pistolet NANOGUN MX HP Basse résistivité LR</b>	<b>N° GUN</b>	<b>Pistolet NANOGUN MX HP Basse résistivité MR</b>
	<i>NANOGUN MX gun type HP Low Resistivity LR</i>		<i>NANOGUN MX gun type HP Low Resistivity MR</i>
	CE+UK+C/US		CE+UK+C/US
910021071-075	Basse résistivité 120 bars	910025956-075	Basse résistivité 120 bars
910021071-150	Basse résistivité 120 bars	910025956-150	Basse résistivité 120 bars
910021071-300	Basse résistivité 120 bars	910025956-300	Basse résistivité 120 bars
910021077-075	Basse résistivité 200 bars	910025957-075	Basse résistivité 200 bars
910021077-150	Basse résistivité 200 bars	910025957-150	Basse résistivité 200 bars
910021077-300	Basse résistivité 200 bars	910025957-300	Basse résistivité 200 bars
<b>N° GUN</b>	<b>Equipement NANOGUN MX CE+UK</b>	<b>N° GUN</b>	<b>Equipement NANOGUN MX C/US</b>
	<i>Equipment NANOGUN MX CE+UK</i>		<i>Equipment NANOGUN MX C/US</i>
910021113-07	Equipement Nanogun MX HR 120b Ig 7,5 EU	910021113-072	Equipement Nanogun MX HR 120b Ig 7,5 US
910021113-15	Equipement Nanogun MX HR 120b Ig 15 EU	910021113-152	Equipement Nanogun MX HR 120b Ig 15 US
910021113-30	Equipement Nanogun MX HR 120b Ig 30 EU	910021113-302	Equipement Nanogun MX HR 120b Ig 30 US
910021115-07	Equipement Nanogun MX HR 200b Ig 7,5 EU	910021115-072	Equipement Nanogun MX HR 200b Ig 7,5 US
910021115-15	Equipement Nanogun MX HR 200b Ig 15 EU	910021115-152	Equipement Nanogun MX HR 200b Ig 15 US
910021115-30	Equipement Nanogun MX HR 200b Ig 30 EU	910021115-302	Equipement Nanogun MX HR 200b Ig 30 US
910021114-07	Equipement Nanogun MX LR 120b Ig 7,5 EU	910021114-072	Equipement Nanogun MX LR 120b Ig 7,5 US
910021114-15	Equipement Nanogun MX LR 120b Ig 15 EU	910021114-152	Equipement Nanogun MX LR 120b Ig 15 US
910021114-30	Equipement Nanogun MX LR 120b Ig 30 EU	910021114-302	Equipement Nanogun MX LR 120b Ig 30 US
910021116-07	Equipement Nanogun MX LR 200b Ig 7,5 EU	910021116-072	Equipement Nanogun MX LR 200b Ig 7,5 US
910021116-15	Equipement Nanogun MX LR 200b Ig 15 EU	910021116-152	Equipement Nanogun MX LR 200b Ig 15 US
910021116-30	Equipement Nanogun MX LR 200b Ig 30 EU	910021116-302	Equipement Nanogun MX LR 200b Ig 30 US
910025958-07	Equipement Nanogun MX MR 120b Ig 7,5 EU	910025958-072	Equipement Nanogun MX MR 120b Ig 7,5 US
910025958-15	Equipement Nanogun MX MR 120b Ig 15 EU	910025958-152	Equipement Nanogun MX MR 120b Ig 15 US
910025958-30	Equipement Nanogun MX MR 120b Ig 30 EU	910025958-302	Equipement Nanogun MX MR 120b Ig 30 US
910025959-07	Equipement Nanogun MX MR 200b Ig 7,5 EU	910025959-072	Equipement Nanogun MX MR 200b Ig 7,5 US
910025959-15	Equipement Nanogun MX MR 200b Ig 15 EU	910025959-152	Equipement Nanogun MX MR 200b Ig 15 US
910025959-30	Equipement Nanogun MX MR 200b Ig 30 EU	910025959-302	Equipement Nanogun MX MR 200b Ig 30 US
<b>N°</b>	<b>Module GNM 6080 CE+UK</b>	<b>N°</b>	<b>Module GNM 6080 C/US</b>
	<i>Control module GNM 6080 CE+UK</i>		<i>Control module GNM 6080 C/US</i>
910017193	Module de commande GNM 6080 version Europe	910017192	Module de commande GNM 6080 version US
<b>N°</b>	<b>Liaison électro-pneumatique CE+UK+C/US</b>		
	<i>Electro-pneumatic coupling set CE+UK+C/US</i>		
910015869-100	Liaison électropneumatique 10m		
910015869-200	Liaison électropneumatique 20m		
910015869-300	Liaison électropneumatique 30m		
<b>N°</b>	<b>Tuyau produit Nanogun MX HR CE+UK+C/US</b>	<b>N°</b>	<b>Tuyau produit Nanogun MX MR CE+UK+C/US</b>
	<i>Nanogun MX HR paint hose CE+UK+C/US</i>		<i>Nanogun MX MR paint hose CE+UK+C/US</i>
910019204-075	Tuyau produit HR 7,5m vert D: 5	910025953-075	Tuyau produit LR vert 7,5m D: 5
910019204-150	Tuyau produit HR 15m vert D: 5	910025953-150	Tuyau produit LR vert 15m D: 5
910019204-300	Tuyau produit HR 30m vert D: 5	910025953-300	Tuyau produit LR vert 30m D: 5
<b>N°</b>	<b>Tuyau produit Nanogun MX LR CE+UKCA+C/US</b>		
	<i>Nanogun MX LR paint hose CE+UK+C/US</i>		
910020165-075	Tuyau produit LR PTFE 7,5m D: 5		
910020165-150	Tuyau produit LR PTFE 15m D: 5		
910020165-300	Tuyau produit LR PTFE 30m D: 5		

DES06562



## 9.2. Configuration

Configuration	GNI 6080 CE 910211183	GNI 6080 US / CSA 91037732	Liaison électro-pneumatique 10m 910012689-100	Liaison électro-pneumatique 20m 910012689-200	Liaison électro-pneumatique 30m 910012689-300	Tuyau HR 7,5m 910021024-075	Tuyau HR 15m 910021024-150	Tuyau HR 30m 910021024-300	Tuyau BR 7,5m 910022595-075	Tuyau BR 15m 910022595-150	Tuyau BR 30m 910022595-300	Buse 09-091 30m 910022595-300
<b>Paquets</b>												
Paquet HR 120 bars sans faisceau	910021070		X		X							X
Paquet HR 120 bars	910021070-075					X						X
Paquet HR 120 bars	910021070-150						X					X
Paquet HR 120 bars	910021070-300							X				X
Paquet LR 120 bars	910021074-075		X						X			X
Paquet LR 120 bars	910021074-150					X						X
Paquet LR 120 bars	910021074-300							X				X
Paquet MR 120 bars	910025958-075		X						X			X
Paquet MR 120 bars	910025958-150					X				X		X
Paquet MR 120 bars	910025958-300							X				X
Paquet HR 200 bars sans faisceau	910021076		X									X
Paquet HR 200 bars	910021076-075					X						X
Paquet HR 200 bars	910021076-150						X					X
Paquet HR 200 bars	910021076-300							X				X
Paquet LR 200 bars	910021077-075		X						X			X
Paquet LR 200 bars	910021077-150					X						X
Paquet LR 200 bars	910021077-300							X				X
Paquet MR 200 bars	910025959-075		X						X			X
Paquet MR 200 bars	910025959-150					X				X		X
Paquet MR 200 bars	910025959-300							X				X
<b>Equipements</b>												
Equipement Nanoogun MKR 120b (g 7,5 EU)	910021113-07	X										X
Equipement Nanoogun MKR 120b (g 15 EU)	910021113-15	X				X						X
Equipement Nanoogun MKR 120b (g 30 EU)	910021113-30	X					X					X
Equipement Nanoogun MKL 120b (g 7,5 EU)	910021114-07	X							X			X
Equipement Nanoogun MKL 120b (g 15 EU)	910021114-15	X								X		X
Equipement Nanoogun MKL 120b (g 30 EU)	910021114-30	X									X	X
Equipement Nanoogun MKR 150b (g 7,5 EU)	910025956-07	X										X
Equipement Nanoogun MKR 150b (g 15 EU)	910025956-15	X										X
Equipement Nanoogun MKR 150b (g 30 EU)	910025956-30	X										X
Equipement Nanoogun MKL 120b (g 7,5 EU)	910021116-07	X							X			X
Equipement Nanoogun MKL 120b (g 15 EU)	910021116-15	X								X		X
Equipement Nanoogun MKL 120b (g 30 EU)	910021116-30	X									X	X
Equipement Nanoogun MKMR 200b (g 7,5 EU)	910025959-07	X										X
Equipement Nanoogun MKMR 200b (g 15 EU)	910025959-15	X										X
Equipement Nanoogun MKMR 200b (g 30 EU)	910025959-30	X										X
Equipement Nanoogun MKHR 120b (g 7,5 US)	910021113-072		X									X
Equipement Nanoogun MKHR 120b (g 15 US)	910021113-152					X						X
Equipement Nanoogun MKHR 120b (g 30 US)	910021113-302							X				X
Equipement Nanoogun MKLR 120b (g 7,5 US)	910021144-072		X						X			X
Equipement Nanoogun MKLR 120b (g 15 US)	910021144-152					X						X
Equipement Nanoogun MKLR 120b (g 30 US)	910021144-302							X				X
Equipement Nanoogun MKMR 120b (g 7,5 US)	910025958-072		X									X
Equipement Nanoogun MKMR 120b (g 15 US)	910025958-152					X						X
Equipement Nanoogun MKMR 120b (g 30 US)	910025958-302							X				X
Equipement Nanoogun MKHR 200b (g 7,5 US)	910021115-072		X									X
Equipement Nanoogun MKHR 200b (g 15 US)	910021115-152					X						X
Equipement Nanoogun MKHR 200b (g 30 US)	910021115-302							X				X
Equipement Nanoogun MKLR 200b (g 7,5 US)	910021116-072		X						X			X
Equipement Nanoogun MKLR 200b (g 15 US)	910021116-152					X						X
Equipement Nanoogun MKLR 200b (g 30 US)	910021116-302							X				X
Equipement Nanoogun MKL 120b (g 7,5 US)	910025959-072		X									X
Equipement Nanoogun MKL 120b (g 15 US)	910025959-152					X						X
Equipement Nanoogun MKL 120b (g 30 US)	910025959-302							X				X

DES06550

## 10. Revision index History

Created by		Checked by: G Fournel	Approved by S. Court
Date	By:	Index	Purpose of the modification and location
2016	S. Court	A	First Issue
2022/11	S. Court	E	Adding UKCA marking Transfer of CSA certification to QPS Change of identity and logo Update of the graphic charter Adding the 4-finger trigger : § 8.2 New HR and LR bases: §8.2 Adding shoulderd washer on air valve § 8.2, 8.6 and § 6.4.6 Adding of needle adjustment procedure §6.4.4.1

## **11. Appendices**

### **11.1. Maintenance preventive plan**

## 11.2. EU and UK Declarations of conformity